

Halley VI defective panel joint detail 3D cutaway

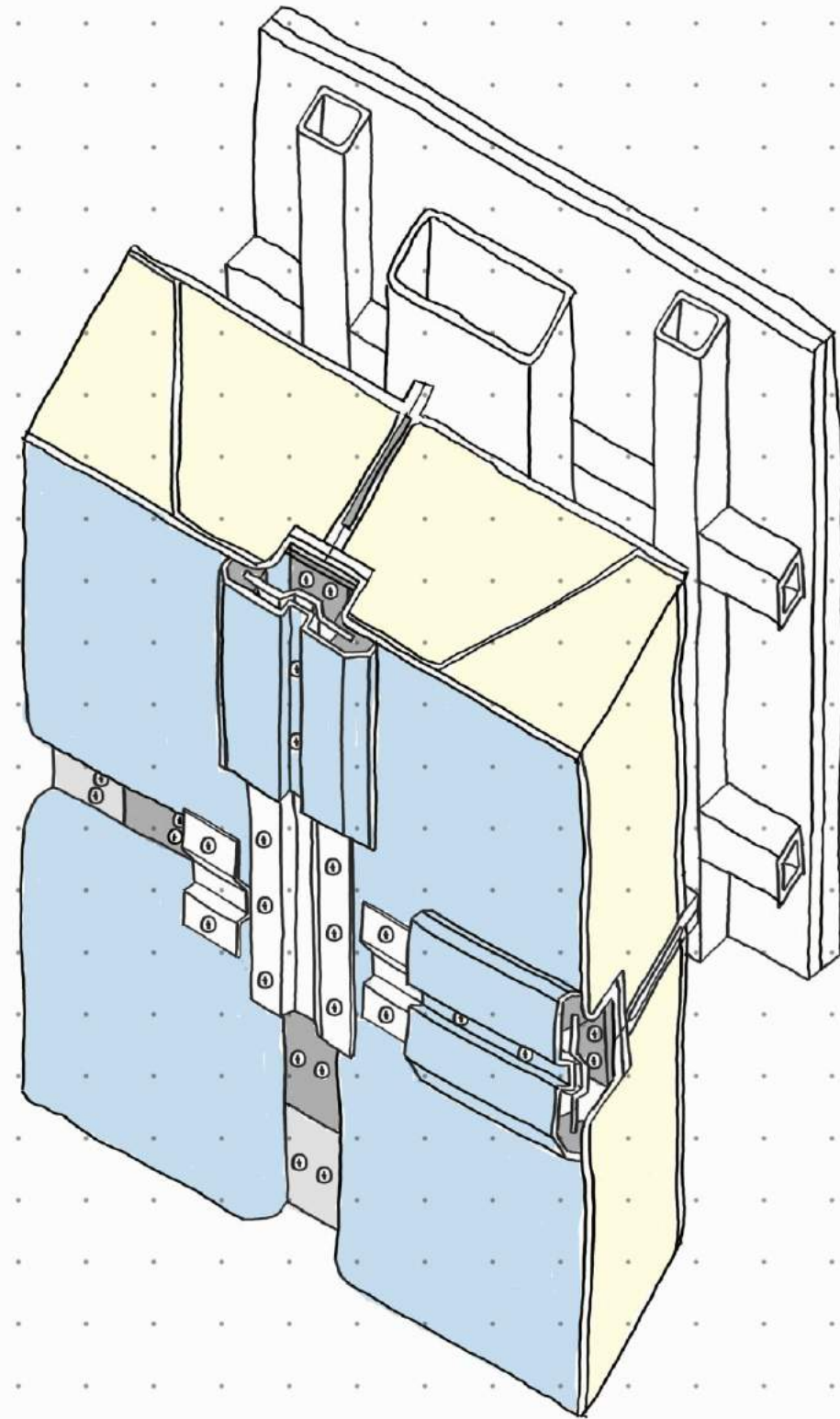

Halley VI amended panel joint detail 3D cutaway

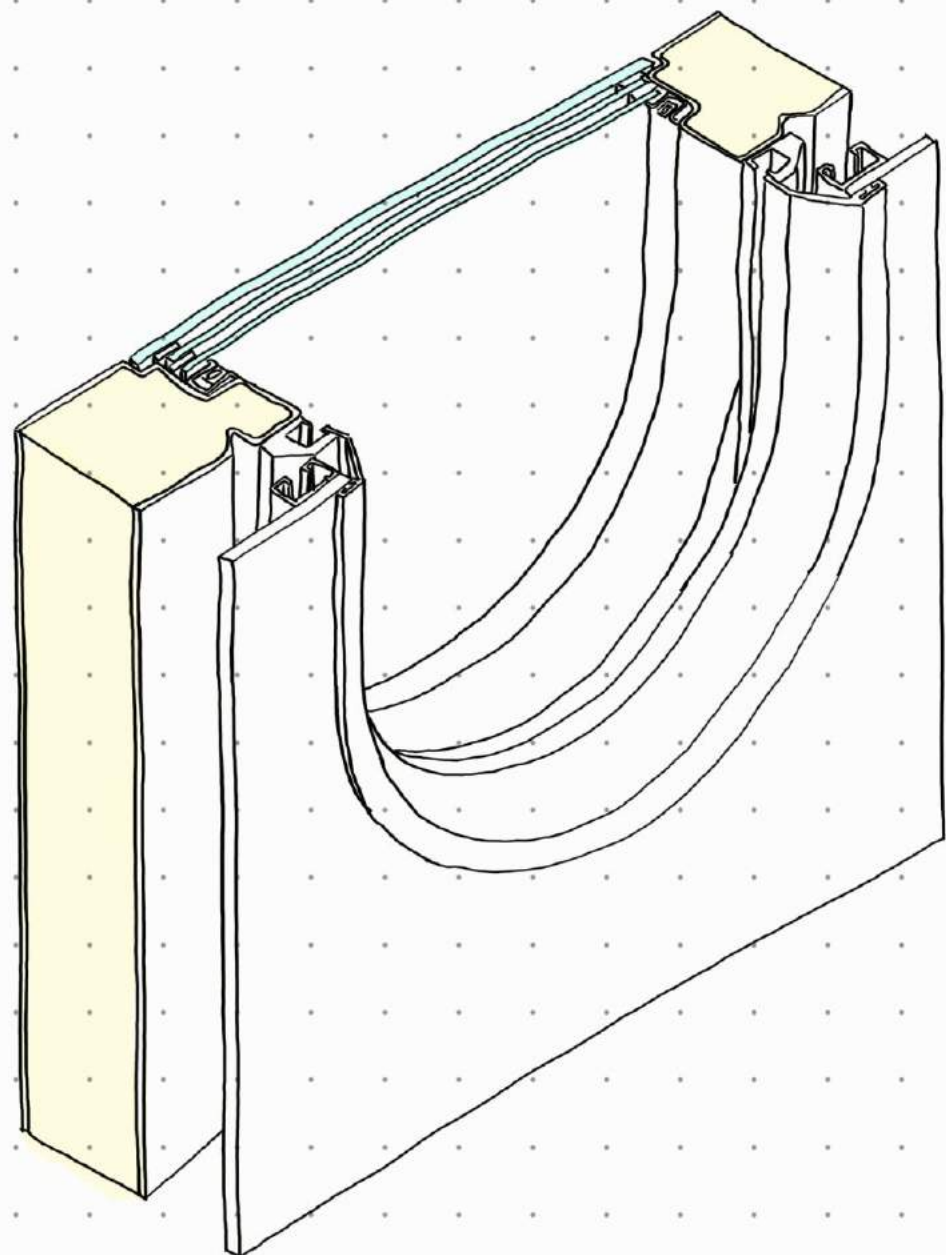

Halley VI 3D window detail

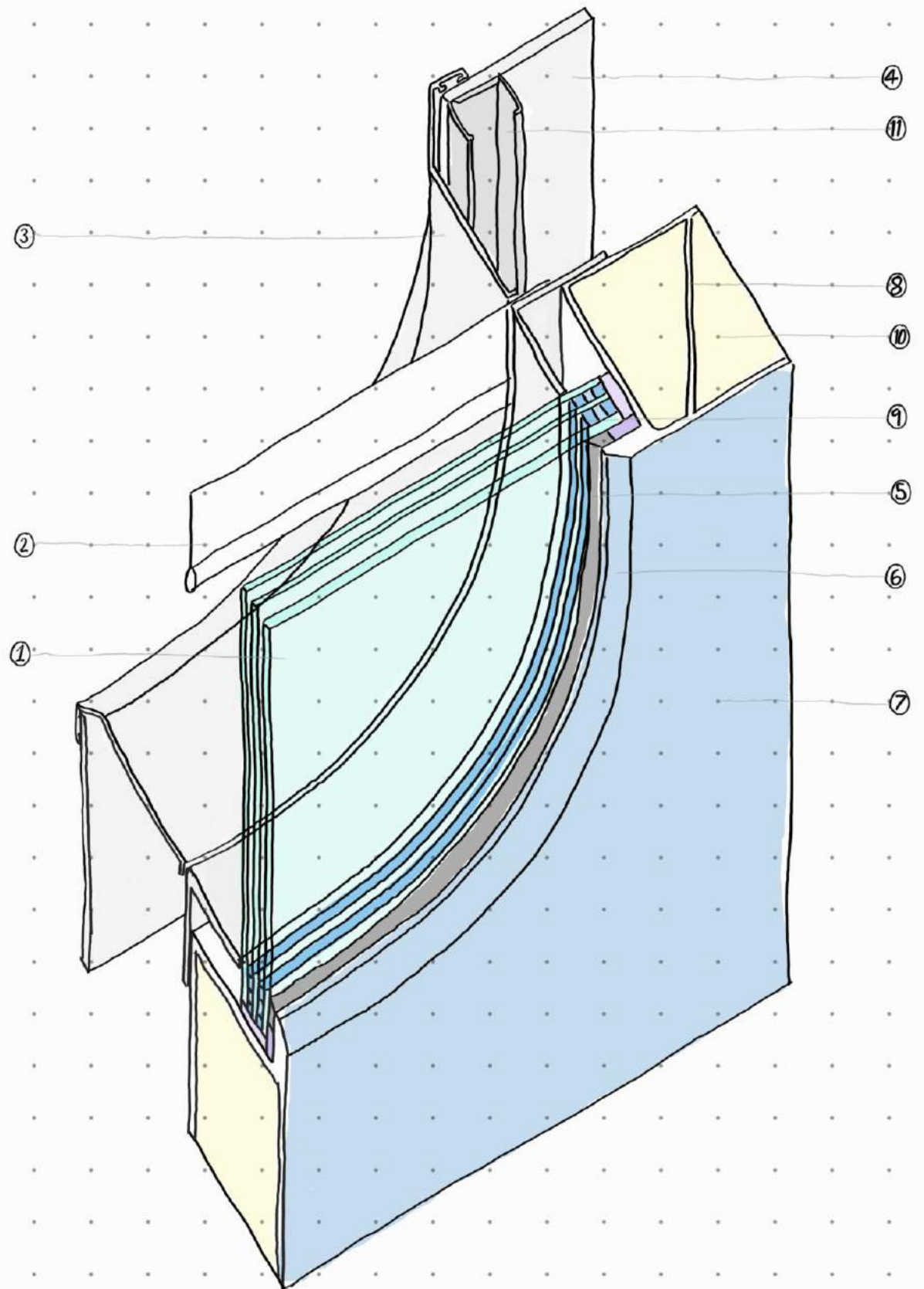

Halley VI 3D window detail

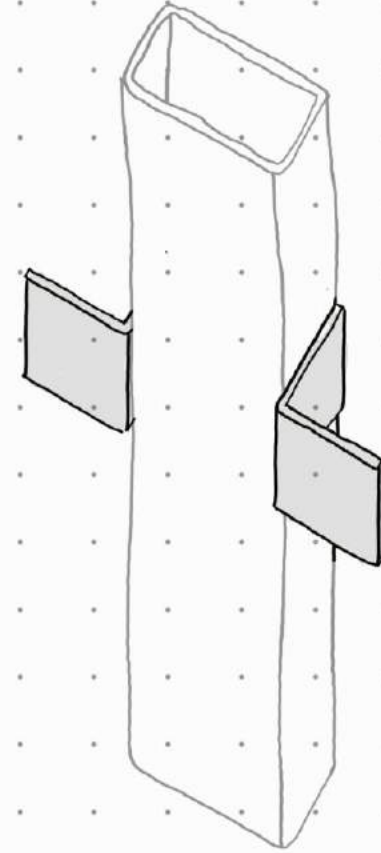
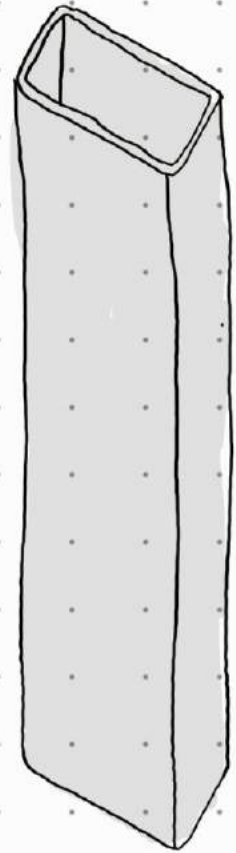

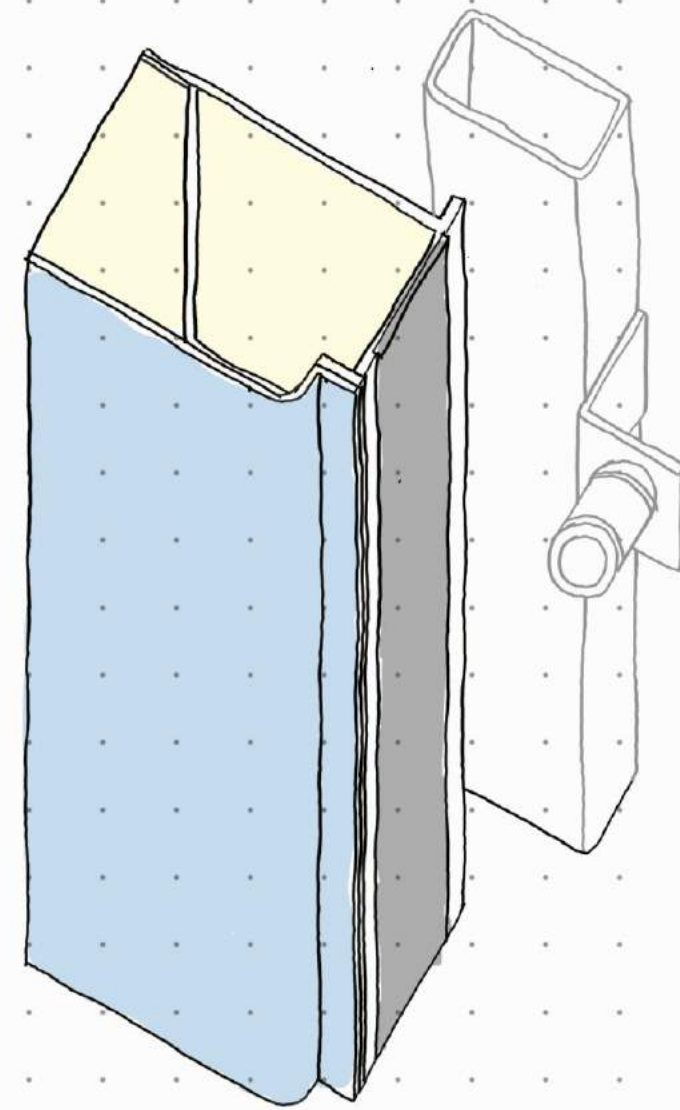
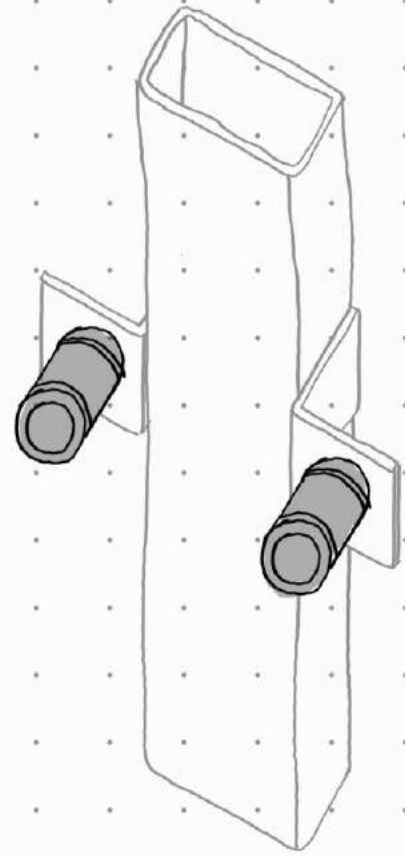

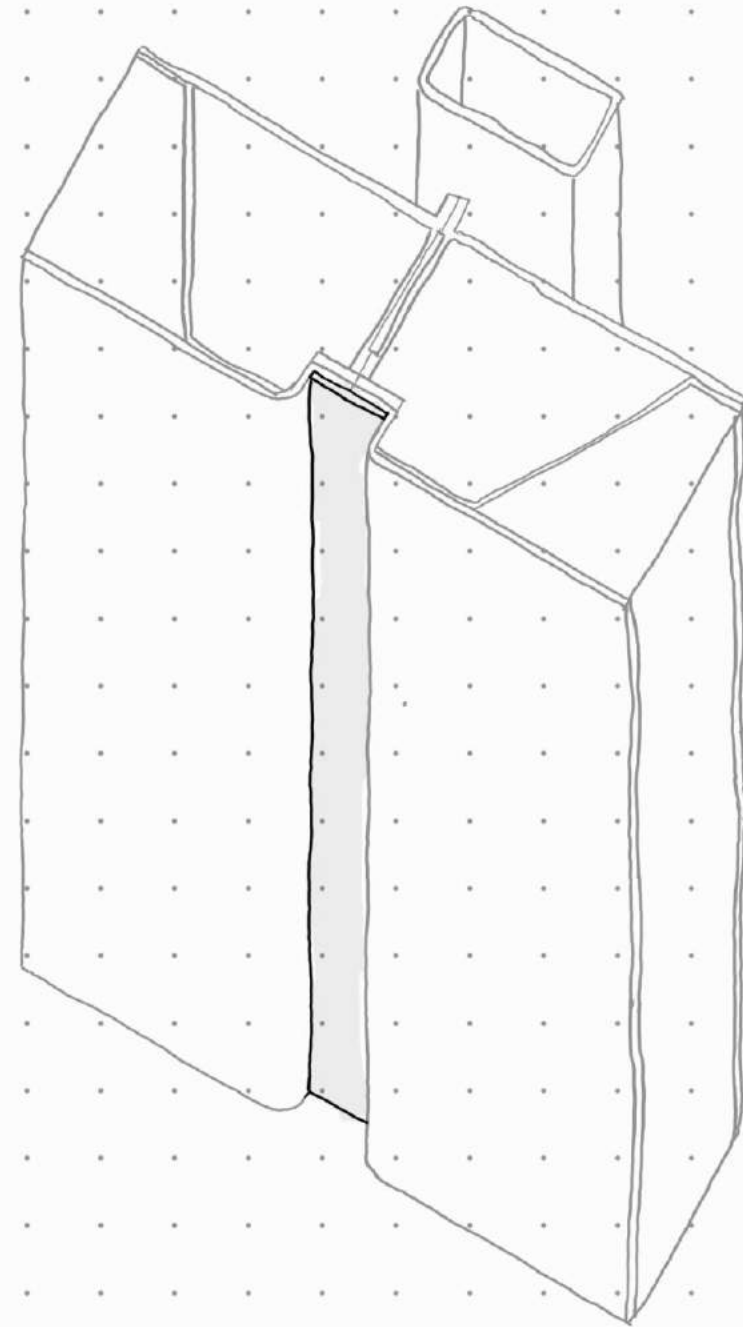
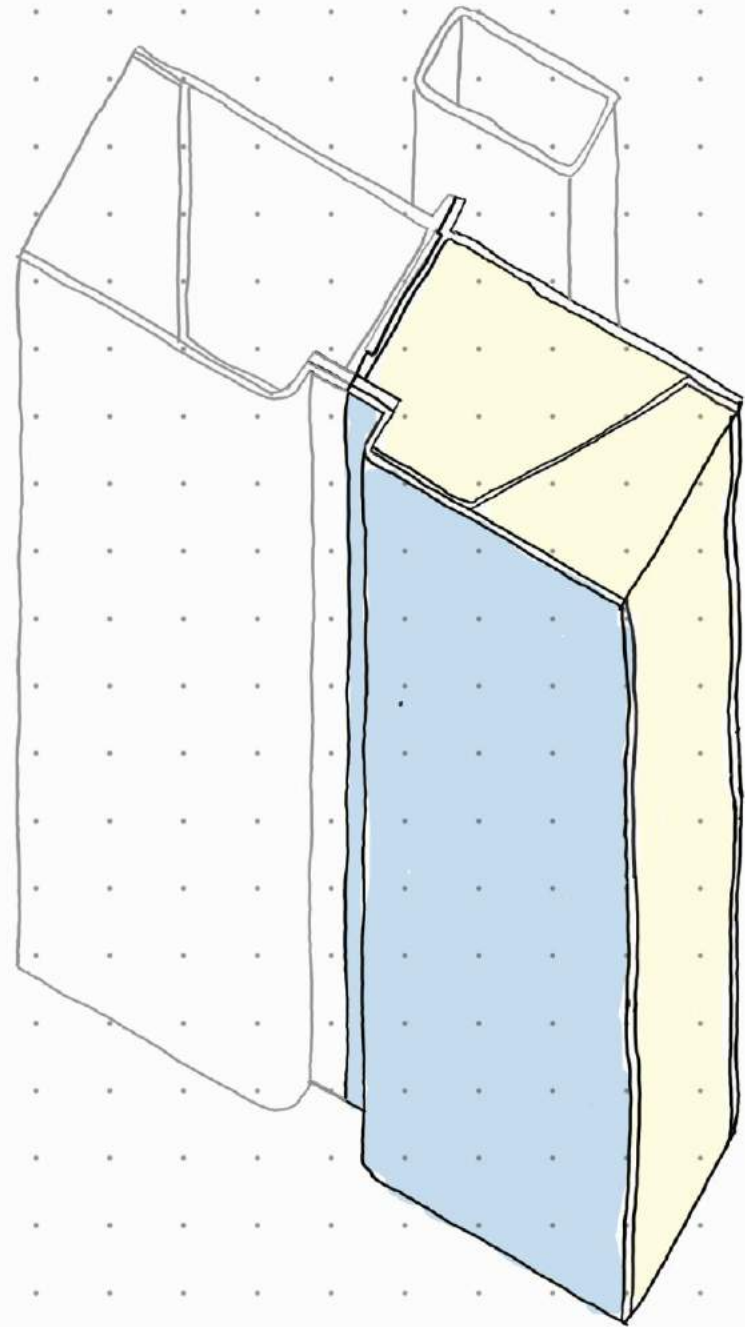

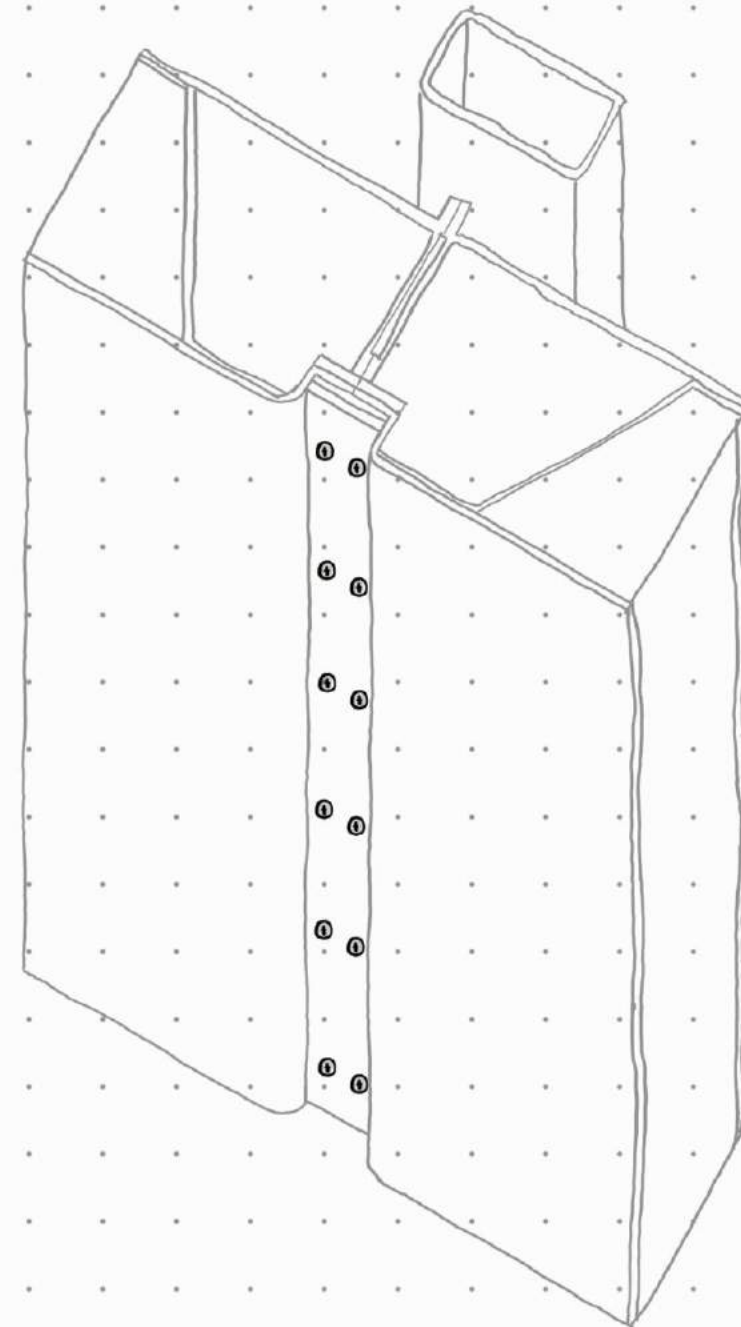
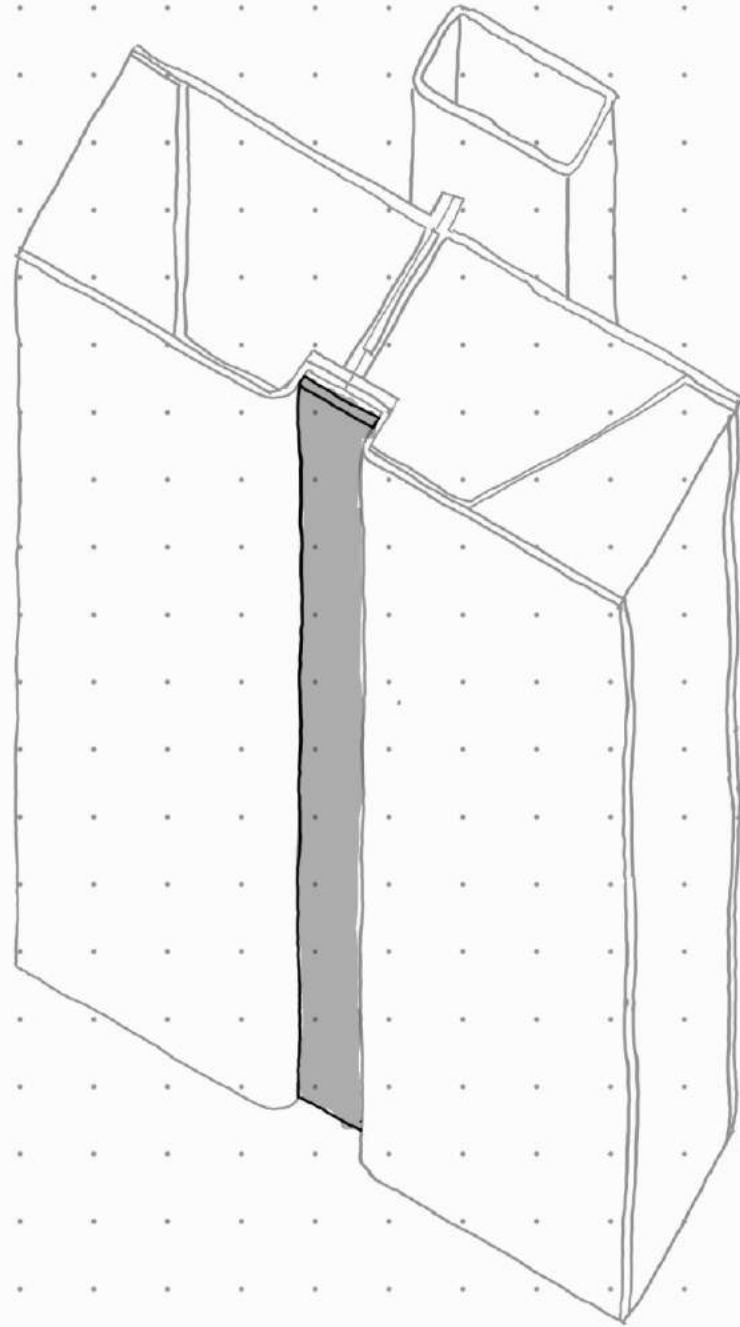

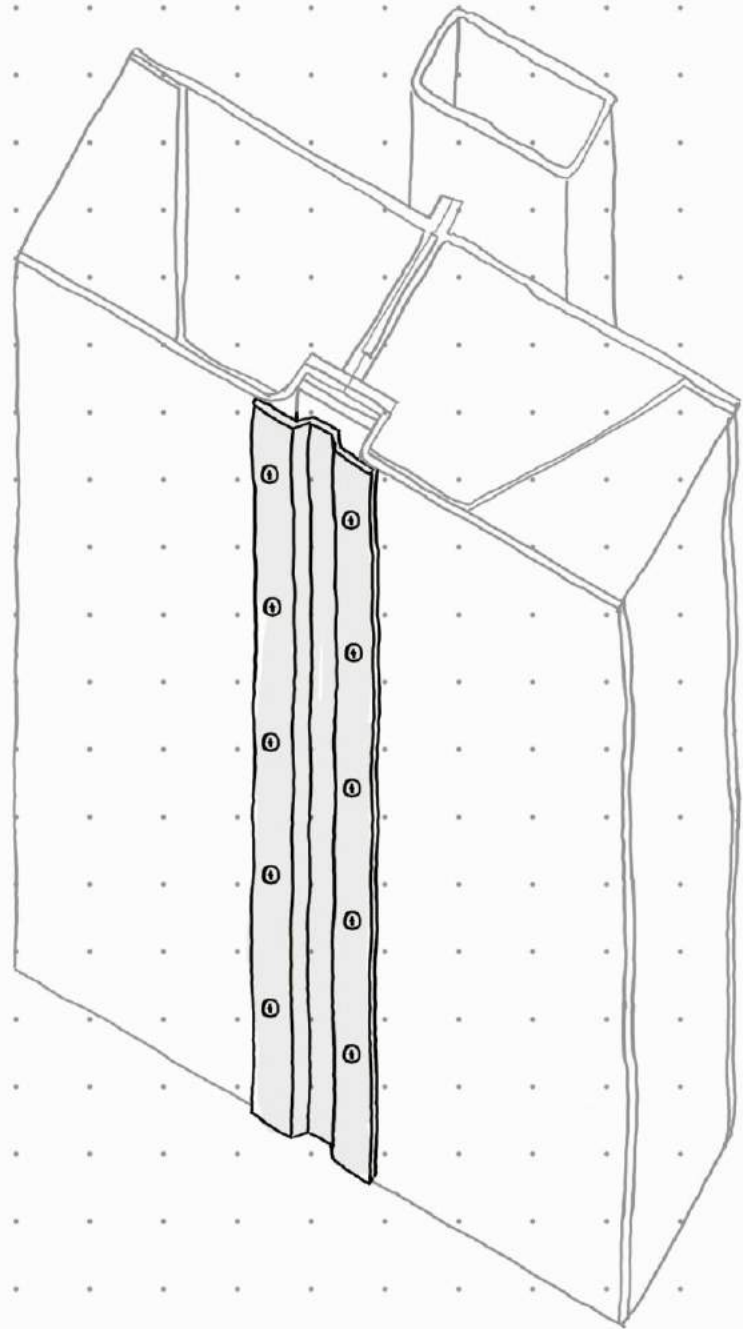

Halley VI external envelope construction séquence

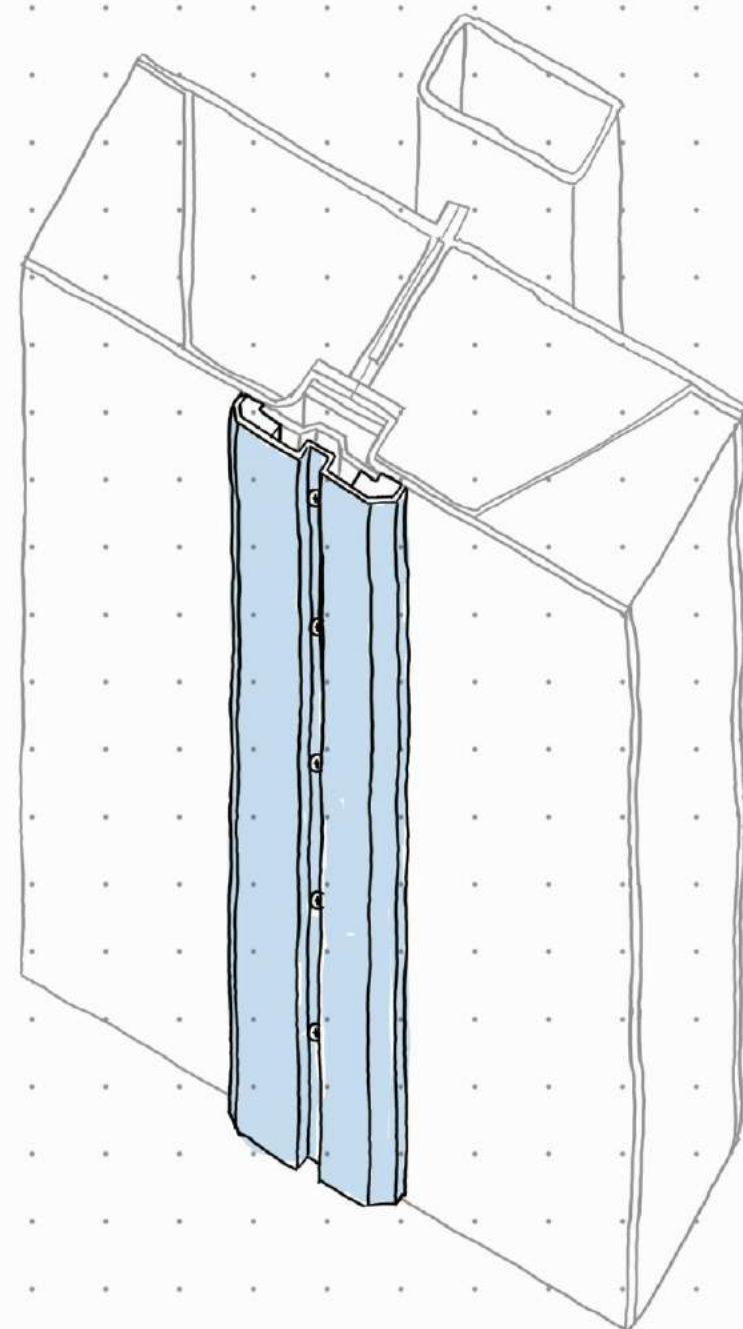

Halley VI external envelope construction séquence

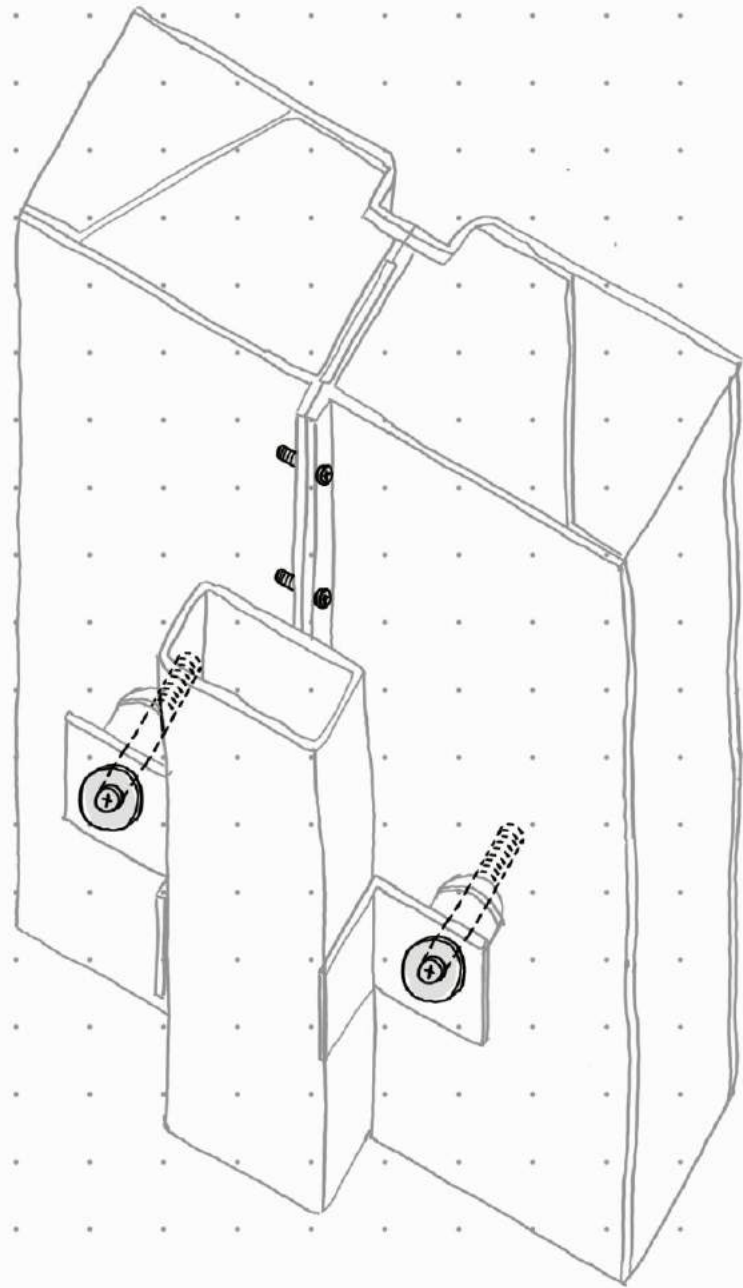

Halley VI external envelope construction séquence

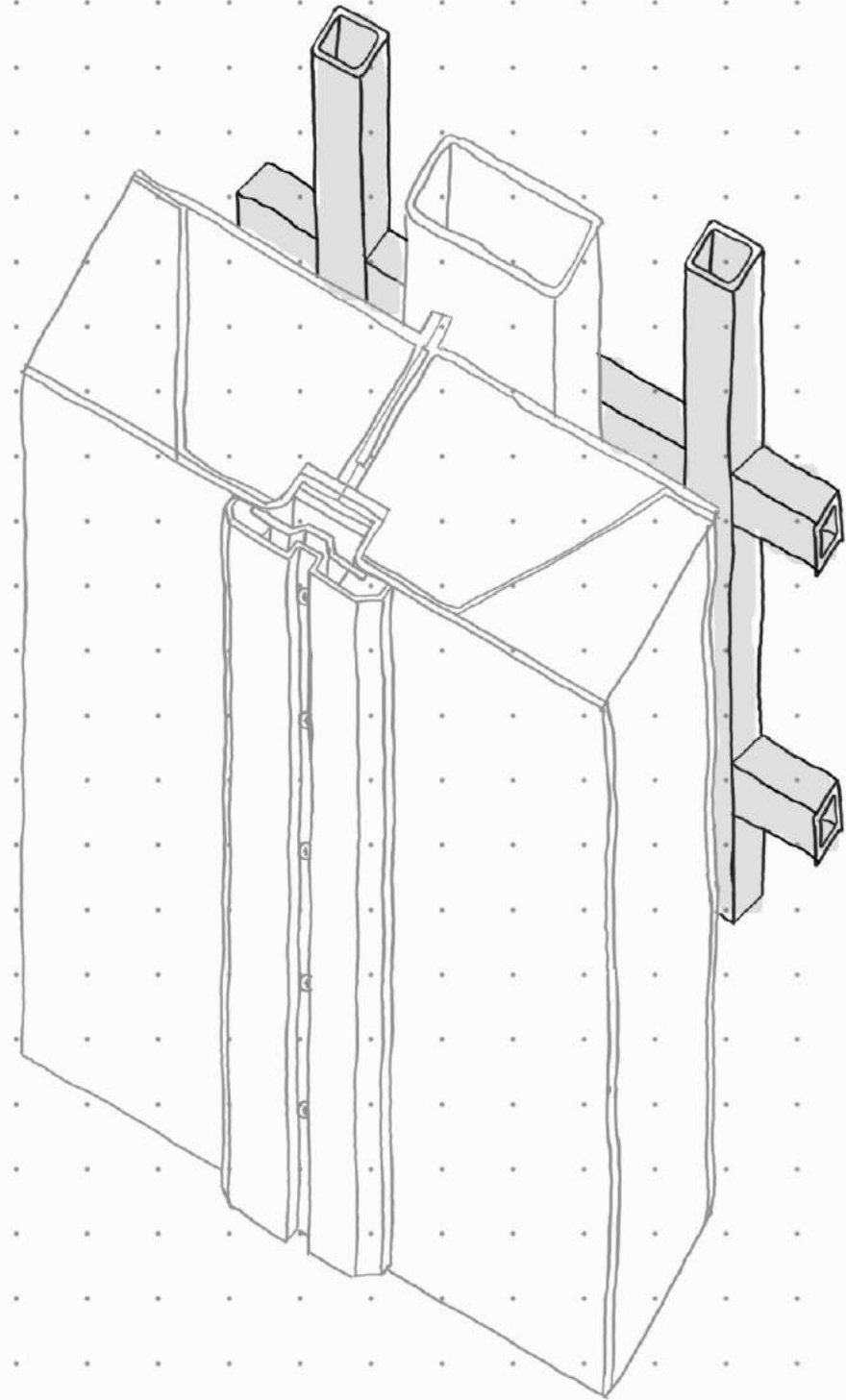

Halley VI external envelope construction séquence

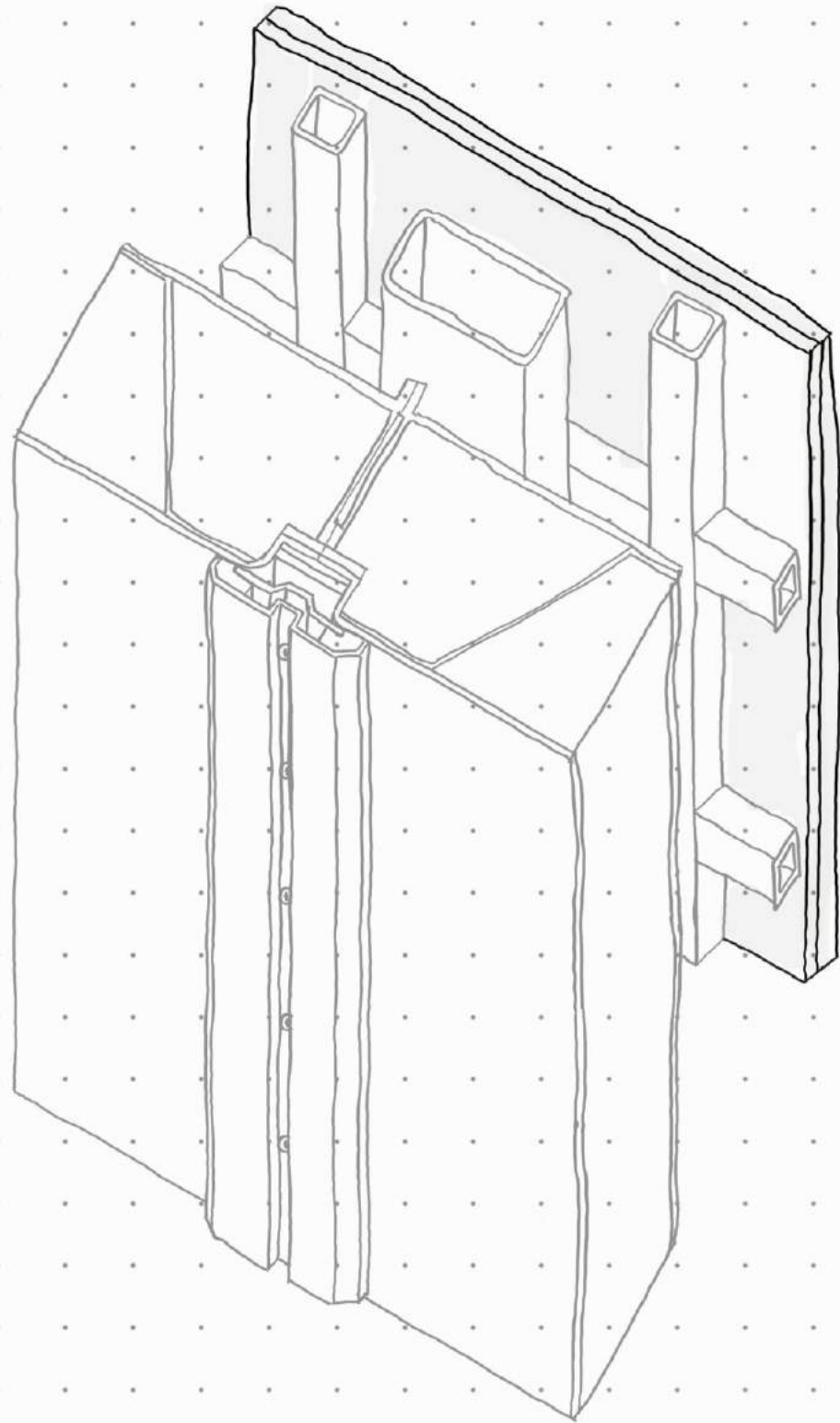

Halley VI external envelope construction séquence

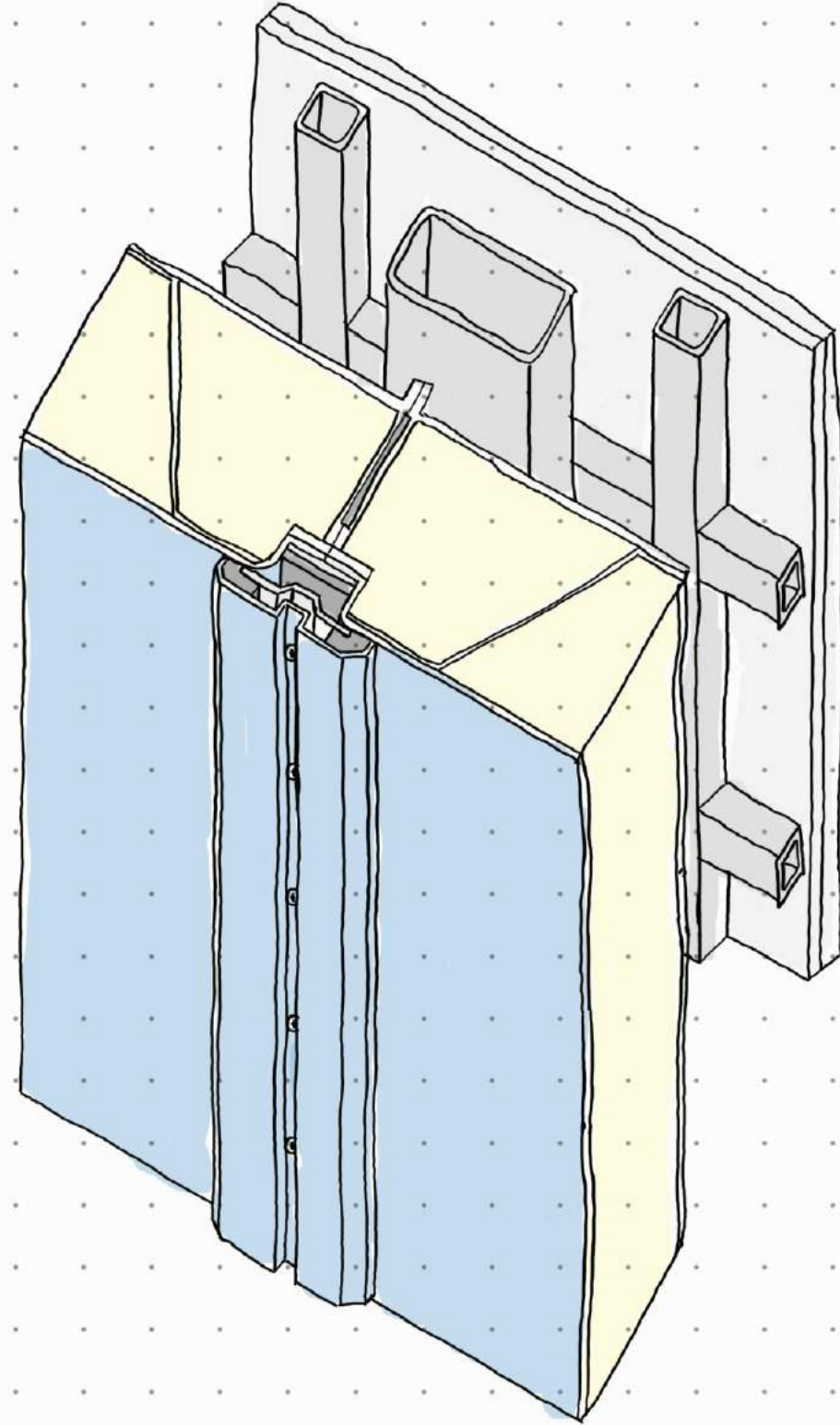

Halley VI external envelope construction séquence

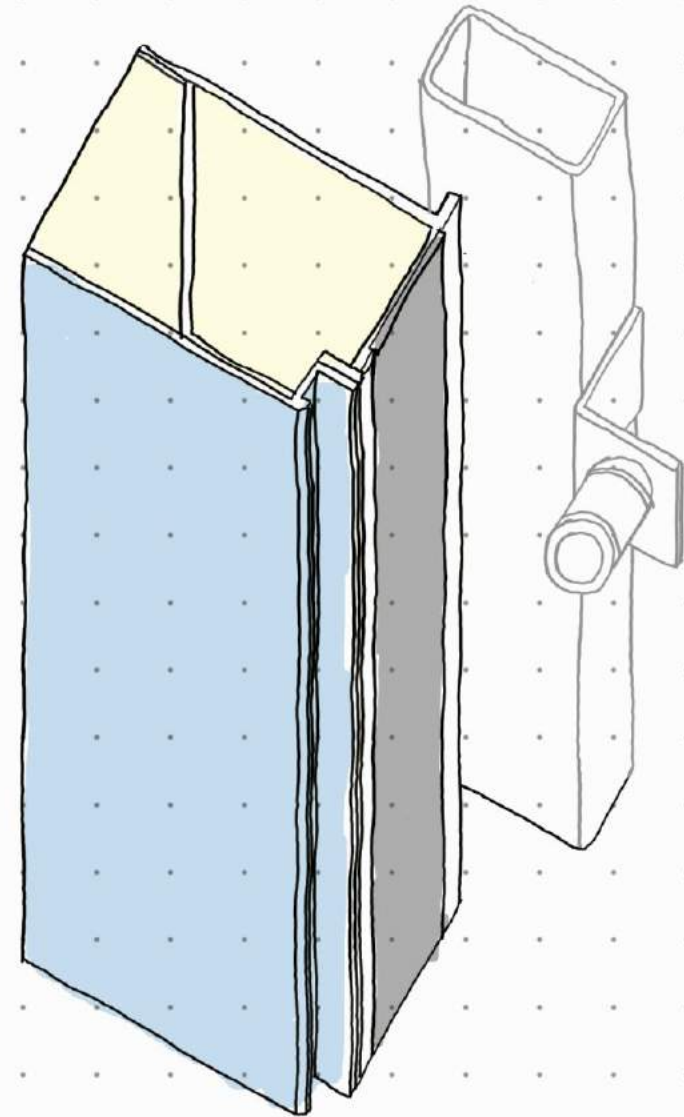
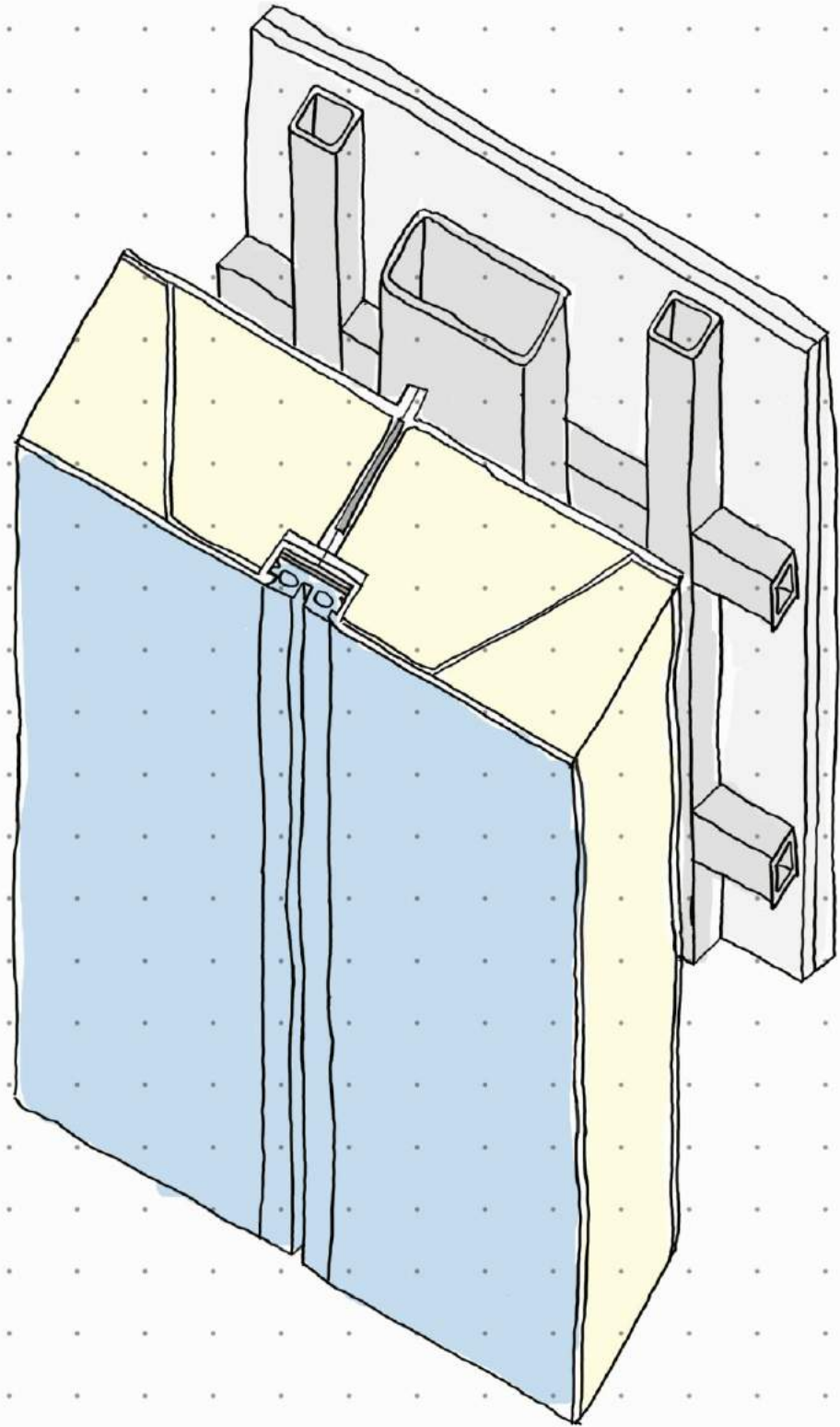

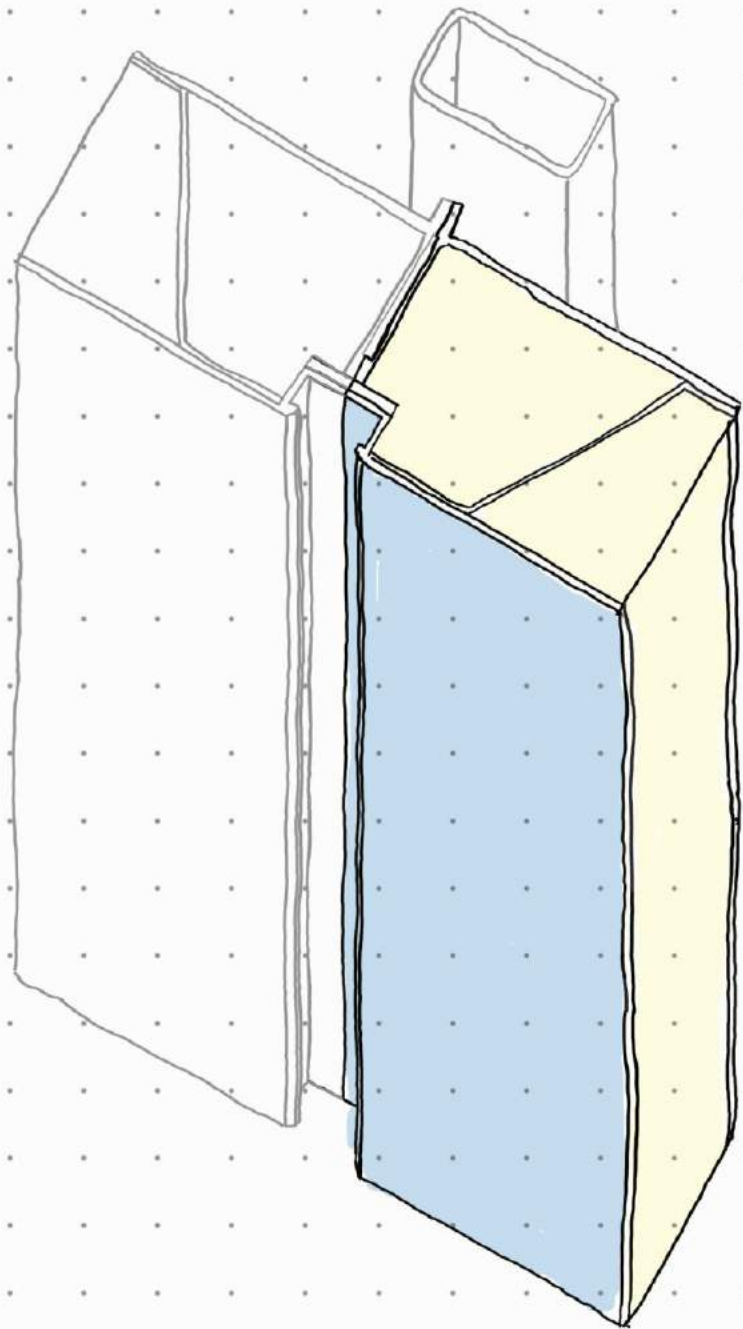

Halley VI external envelope construction séquence

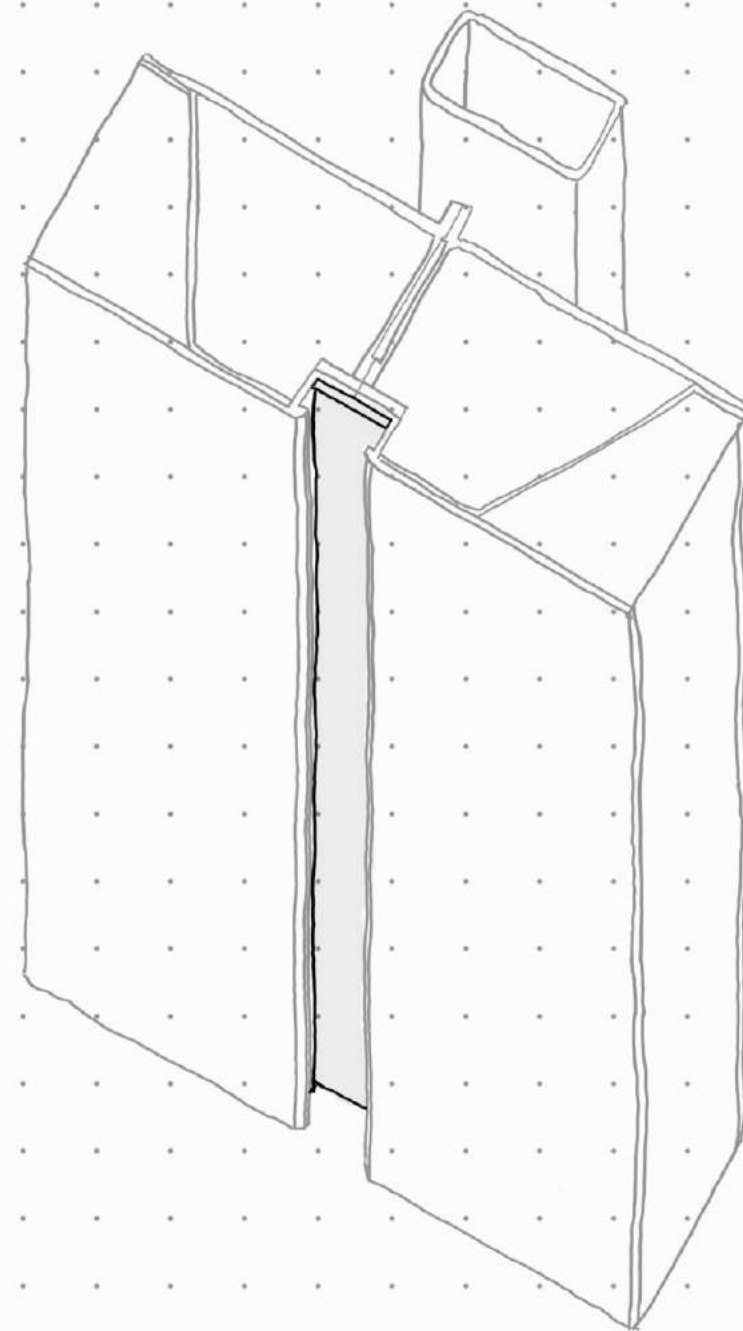

Halley VI external envelope construction séquence

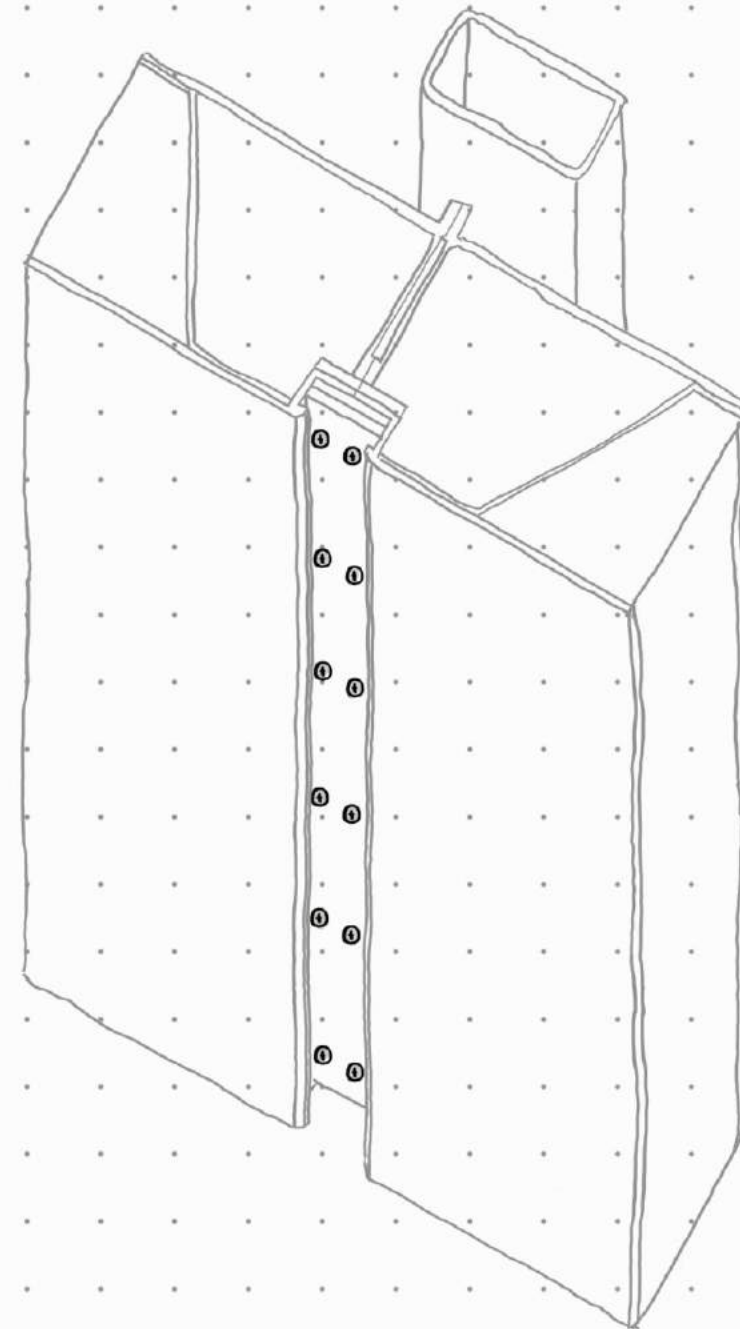
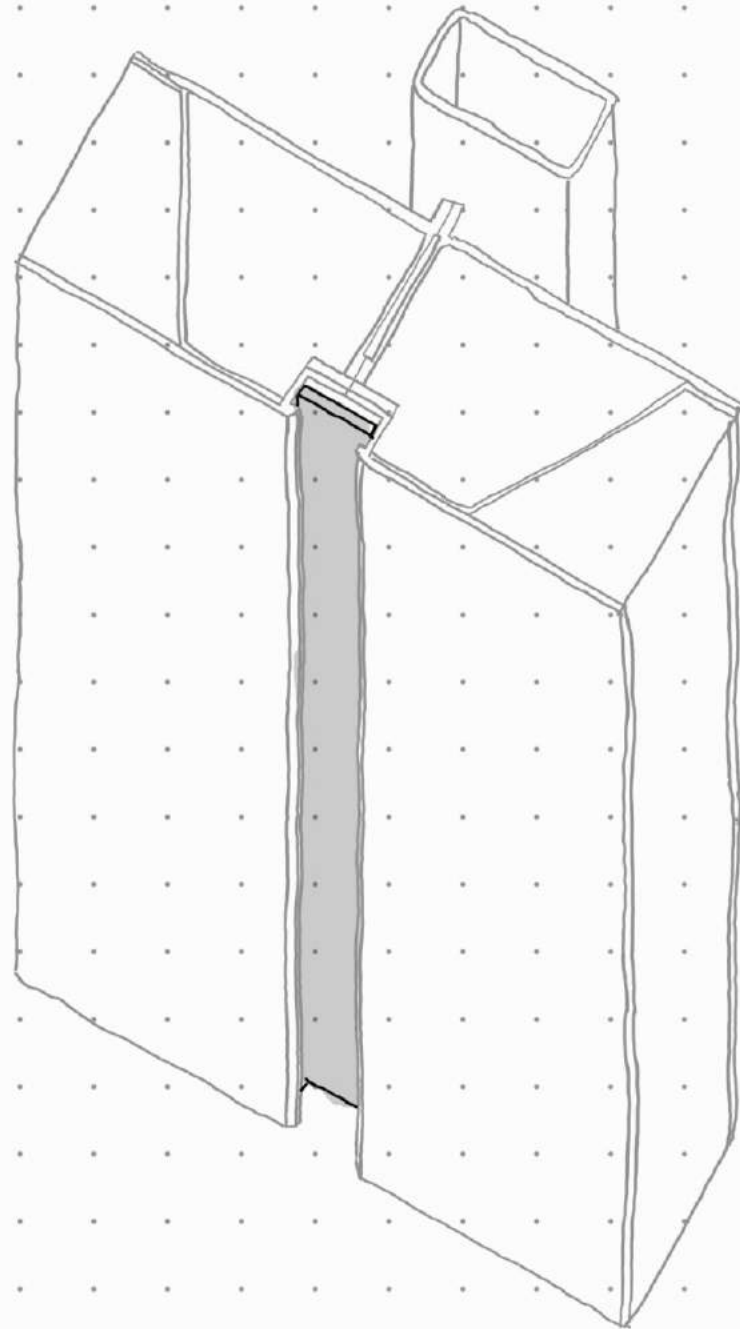

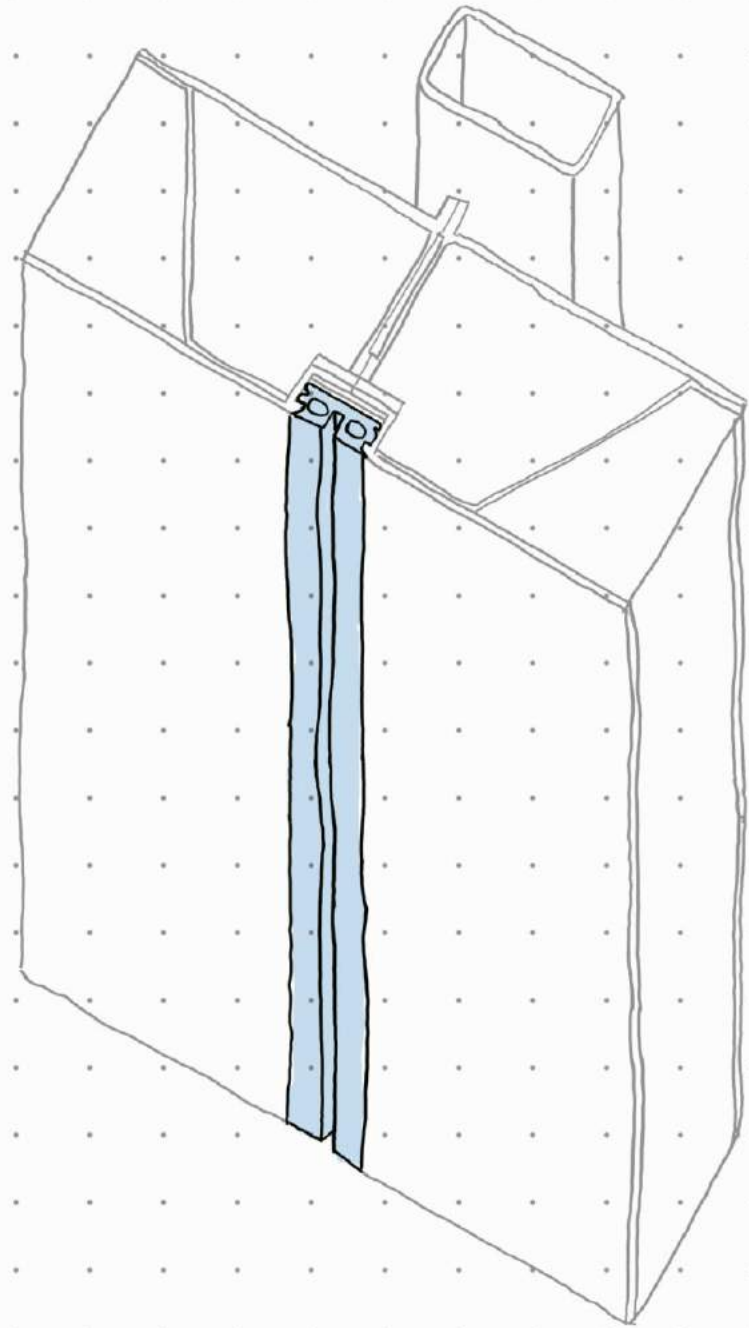

Halley VI external envelope construction séquence

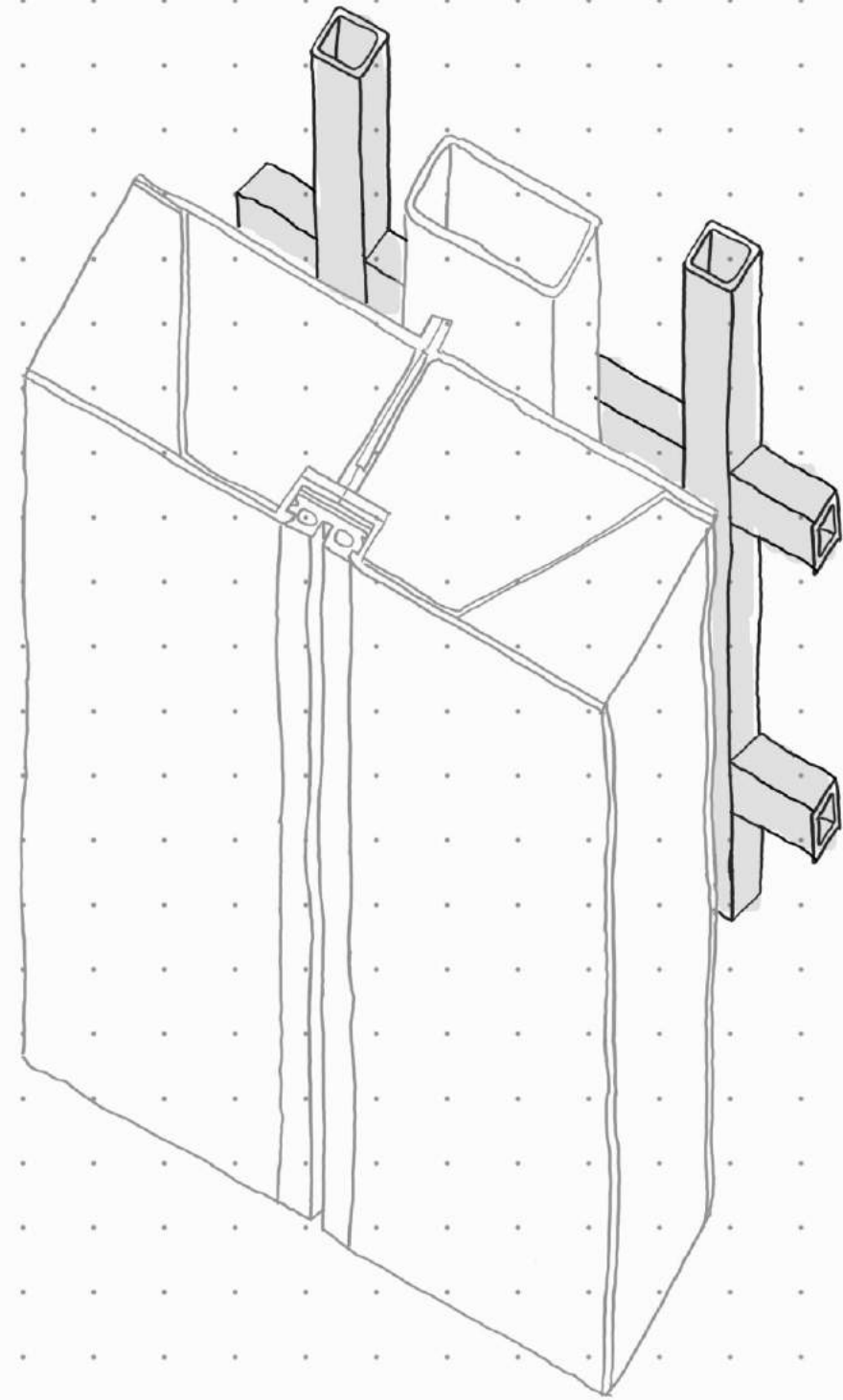

Halley VI external envelope construction séquence

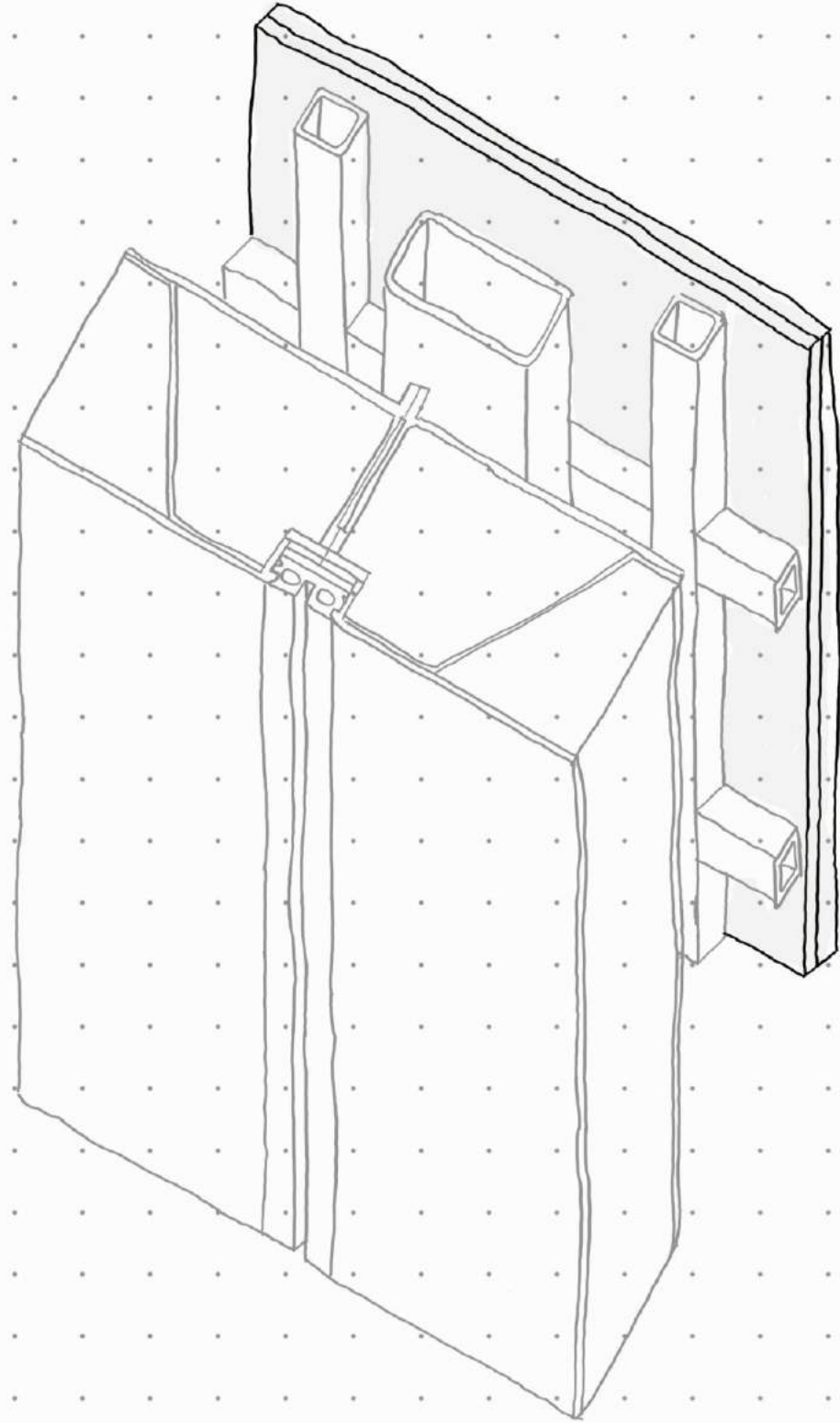

Halley VI external envelope construction séquence

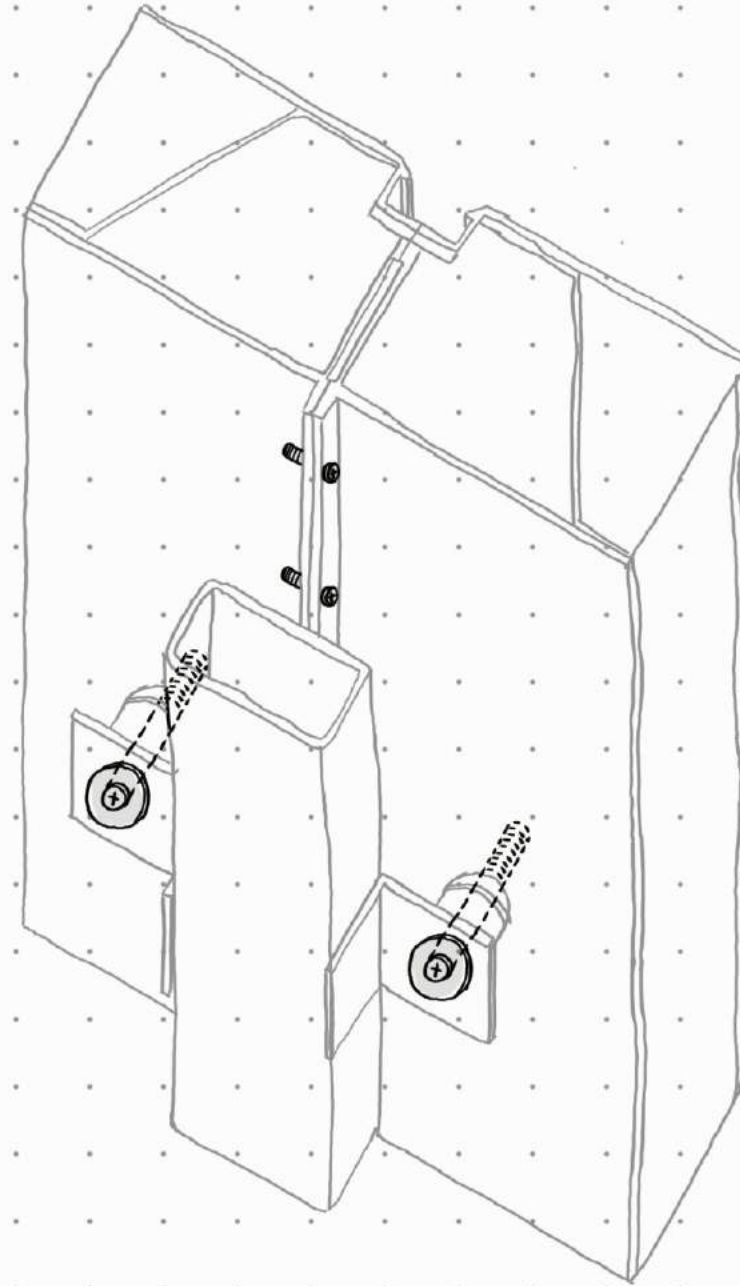

Halley VI external envelope construction séquence

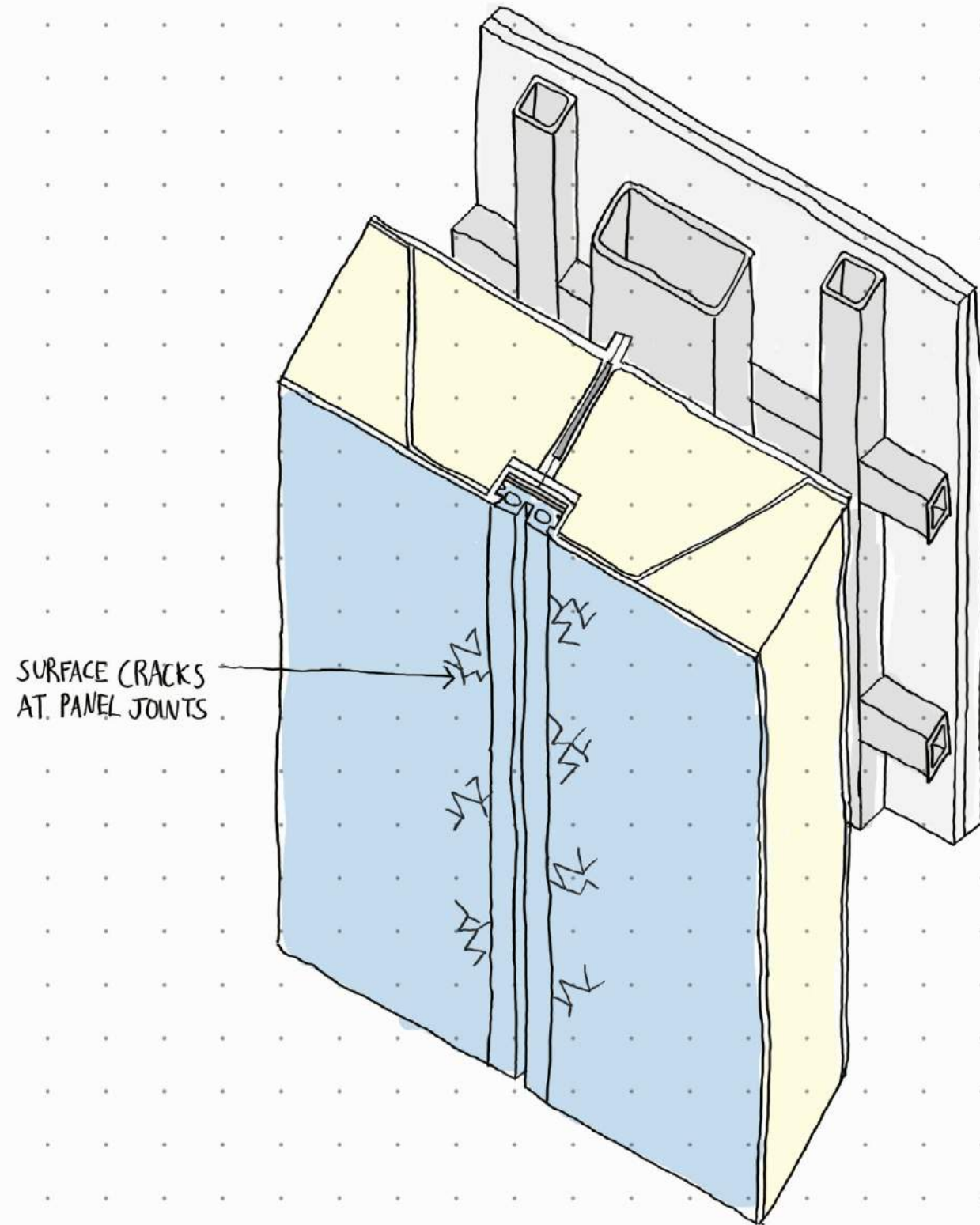

Halley VI panel joint detail defects

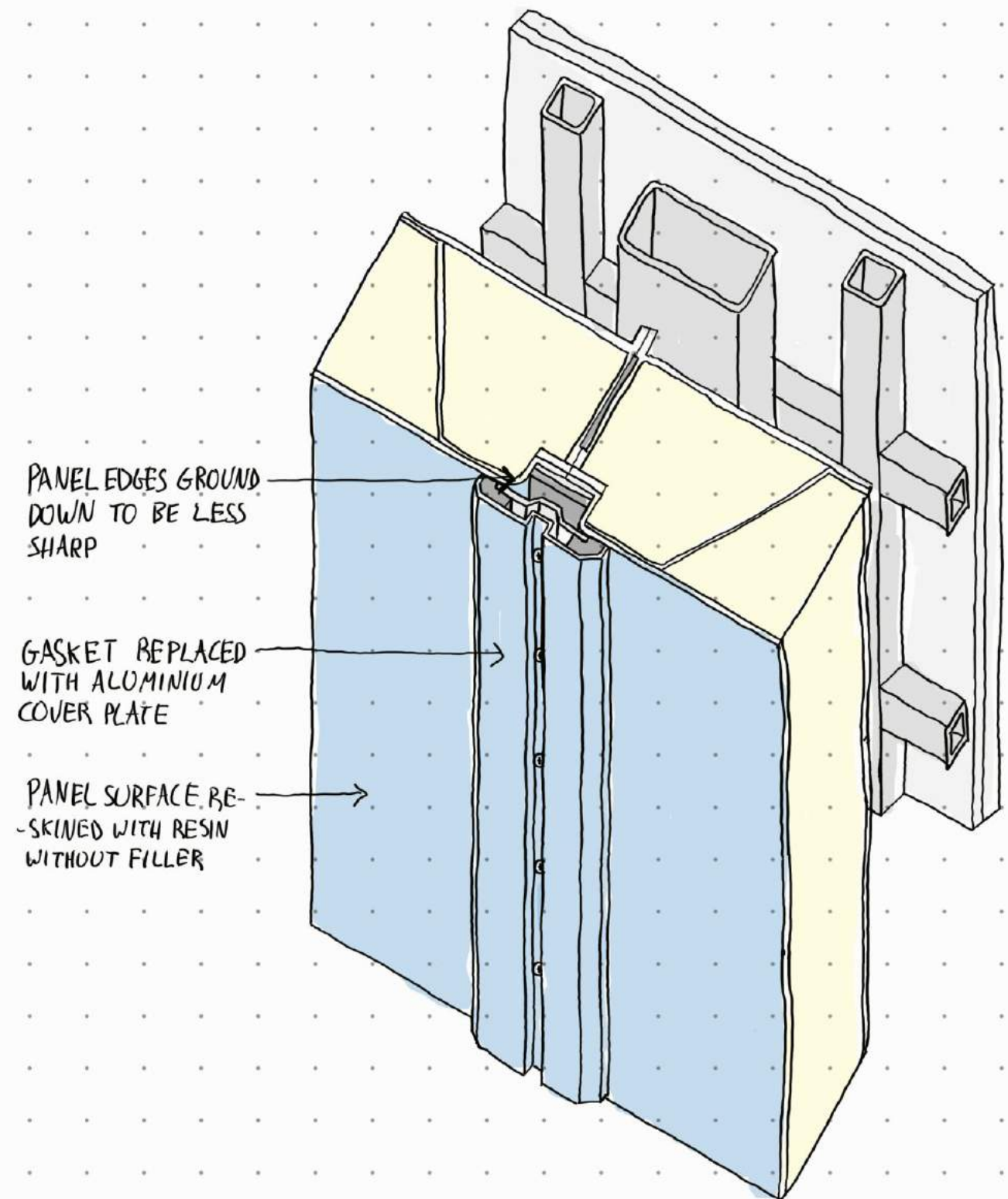

Halley VI panel joint detail amendment

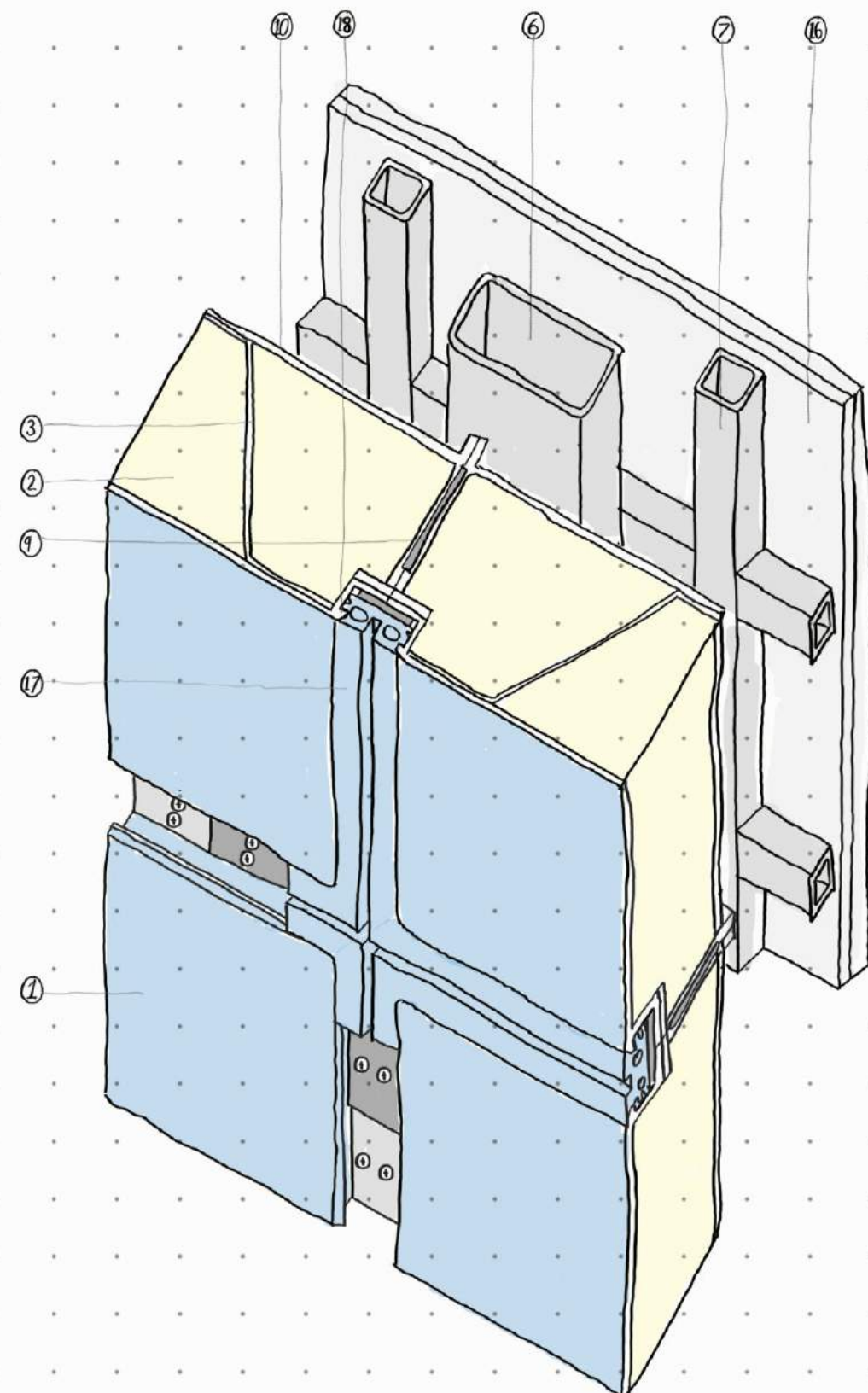
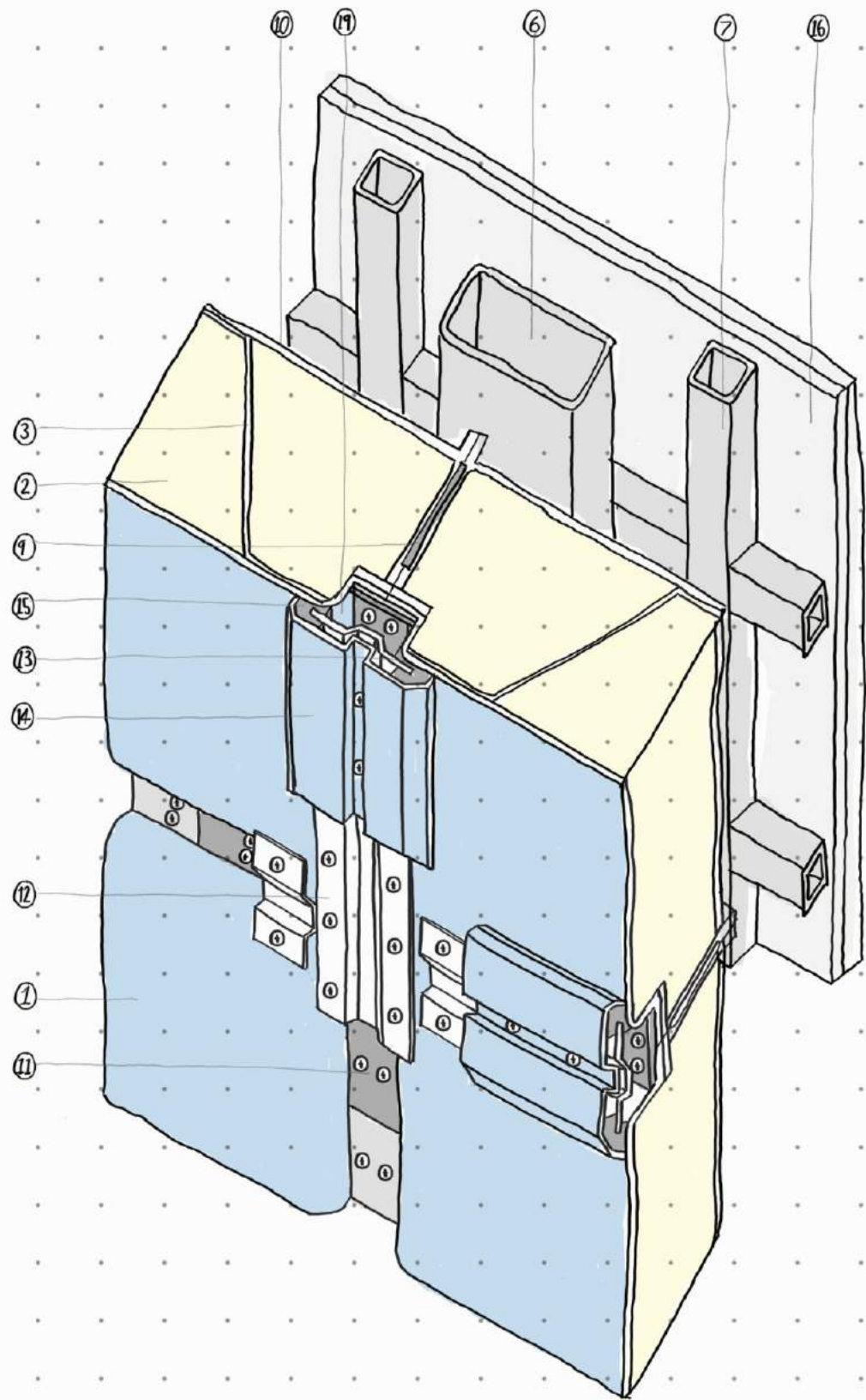

Halley VI amended panel joint 3D detail

Halley VI defective panel joint 3D detail

CROSSFIBRES PREVENT DELAMINATION OF GRP SKIN FROM INSULATION
 NEOPRENE INSULATION AVOIDS COLD BRIDGING AT THE PANEL JOINTS
 SINGLE SKIN PANEL SYSTEM ALLOWS FOR A FAST CONSTRUCTION PROCESS TO AVOID LONG PERIODS OF EXPOSURE TO THE EXTREME WEATHER CONDITIONS

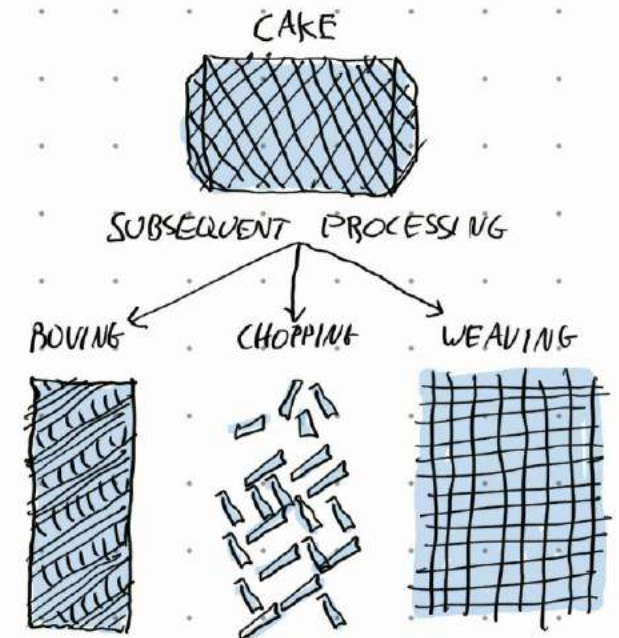
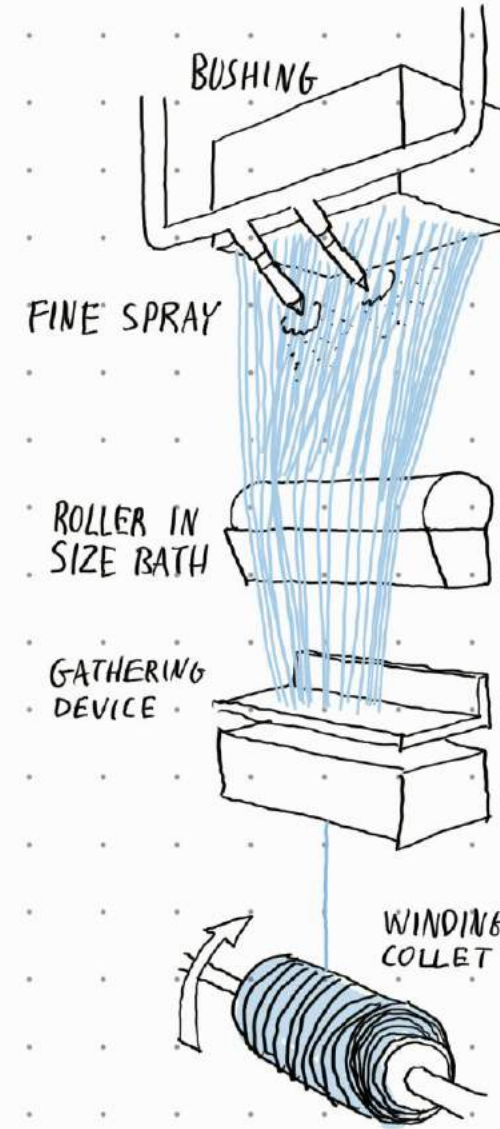
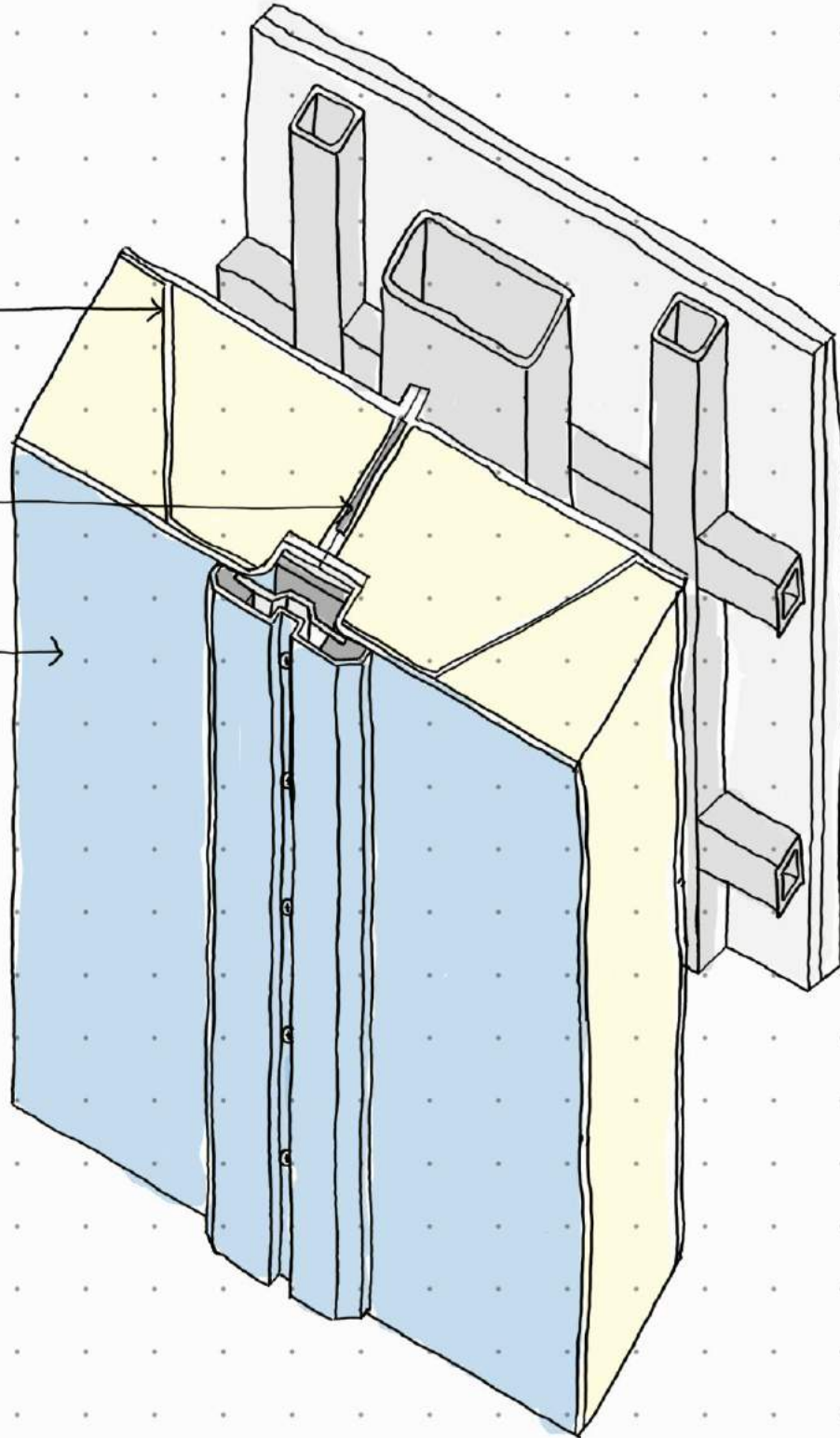

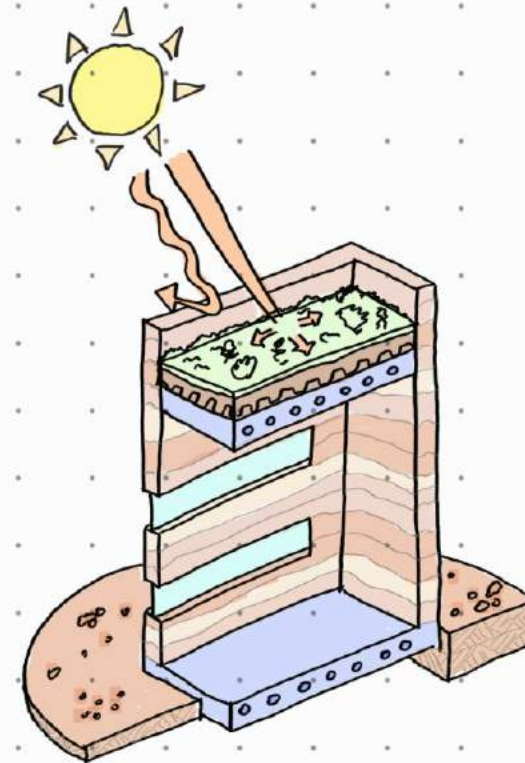
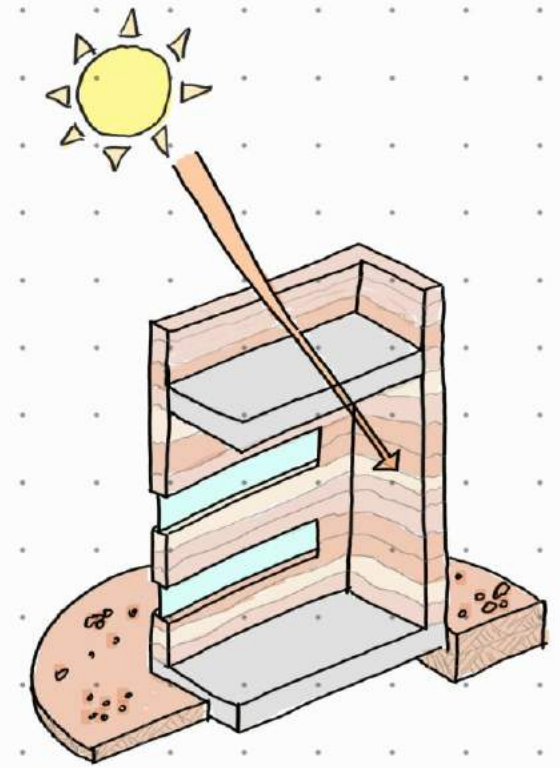
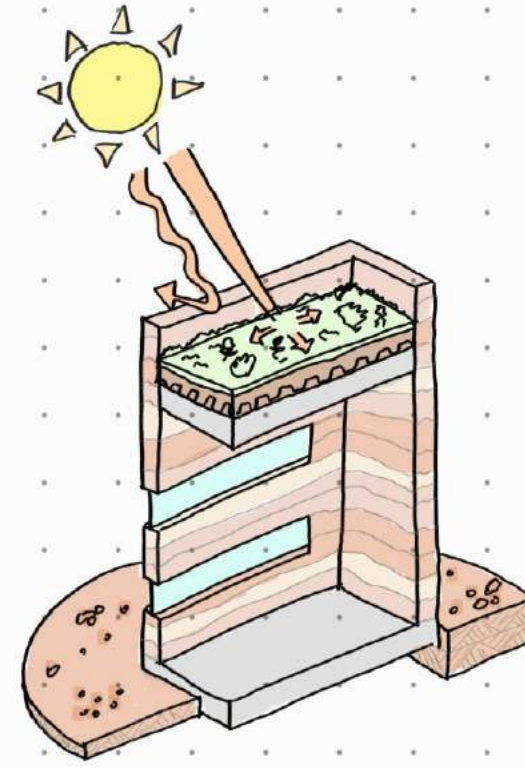
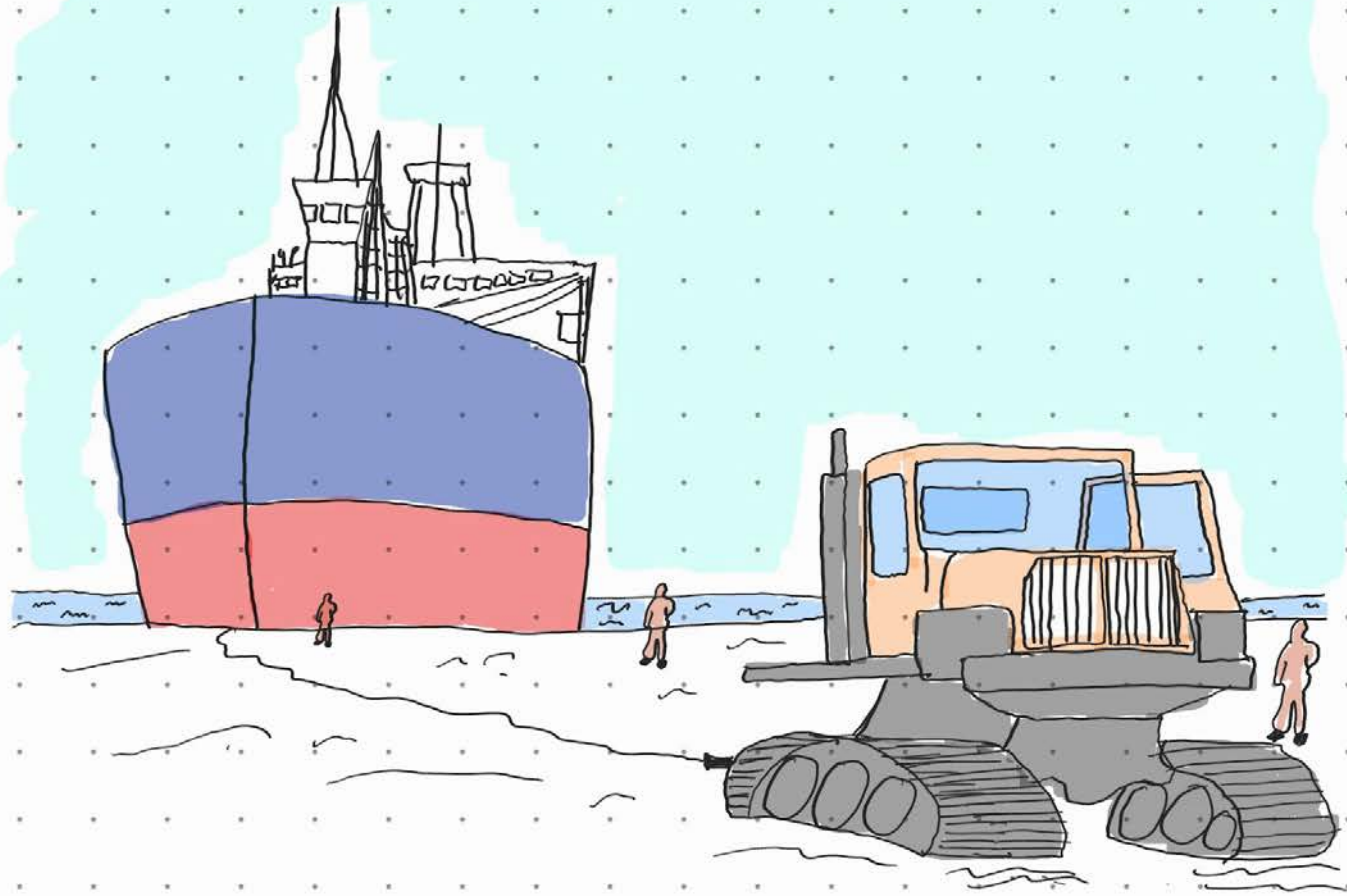

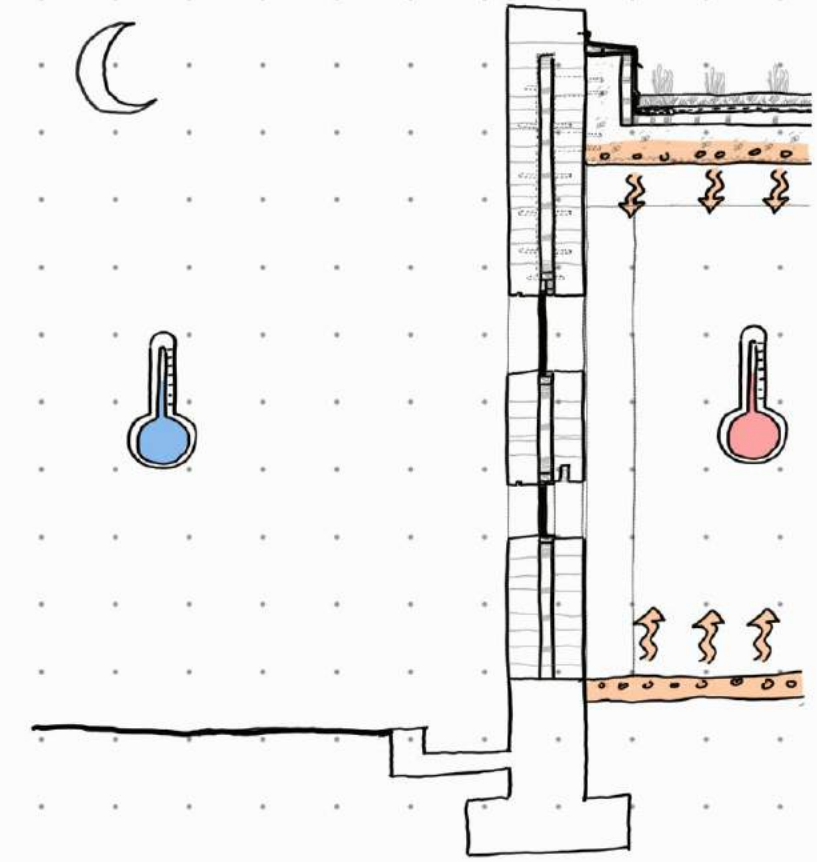
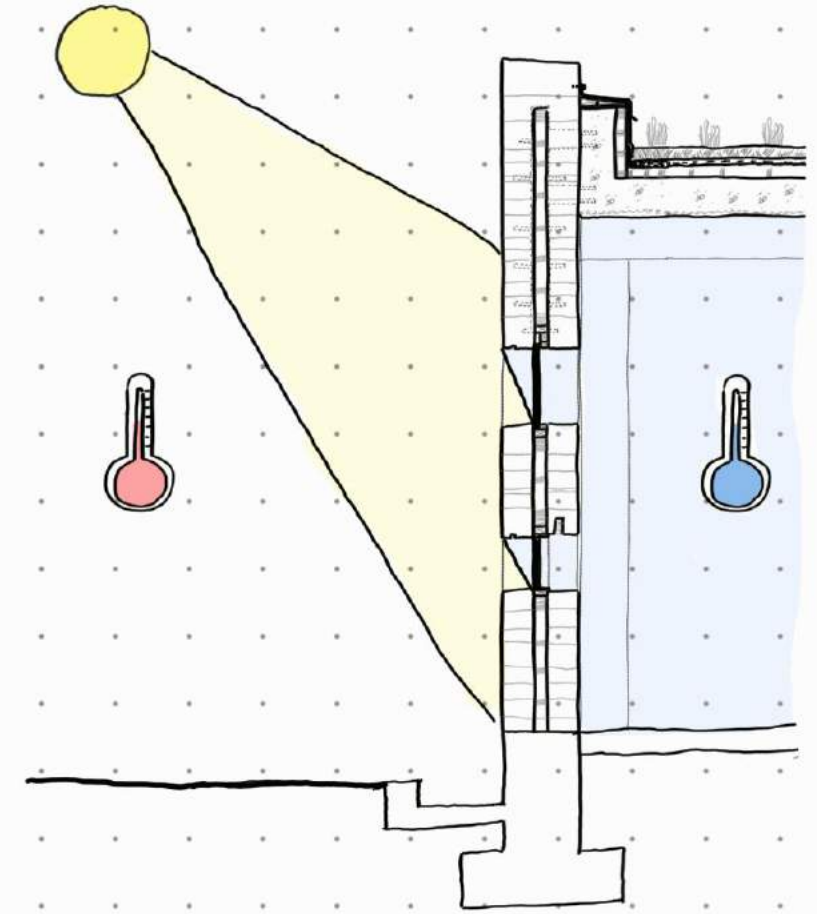
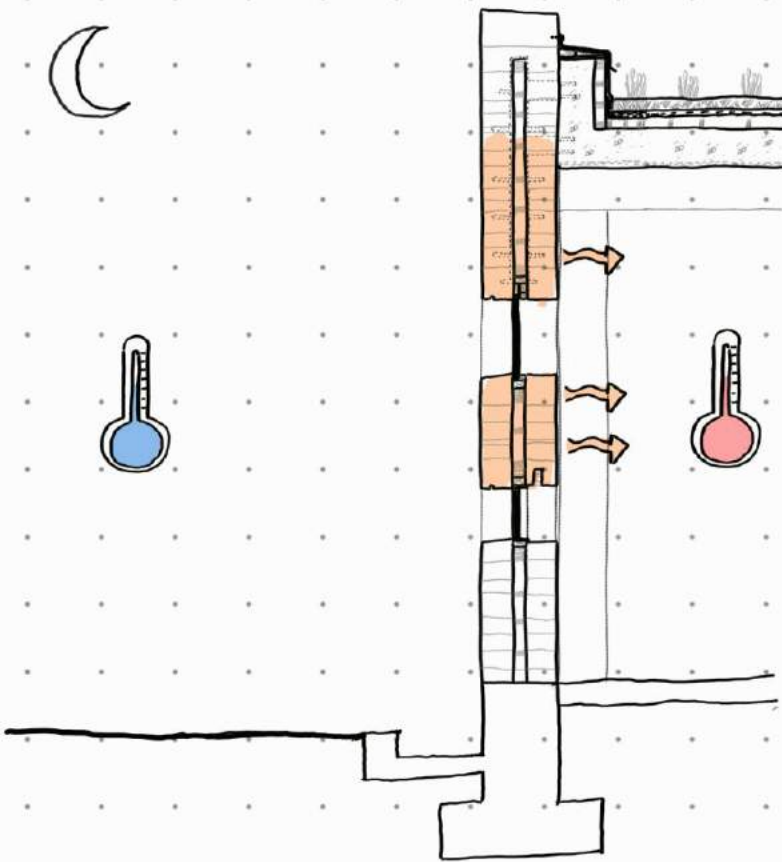
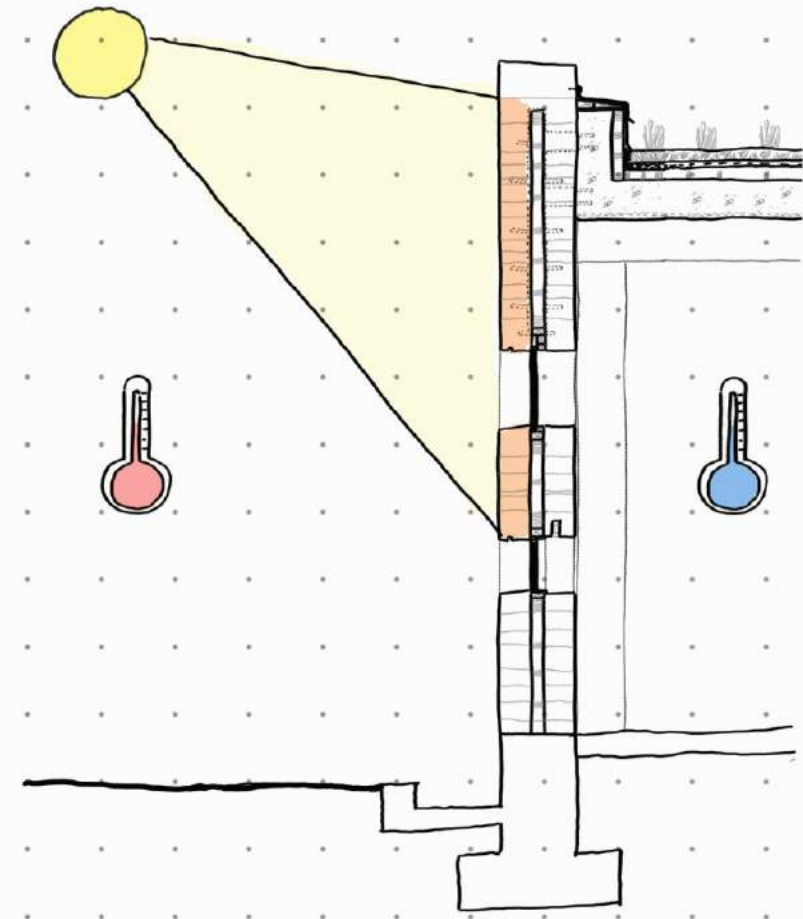

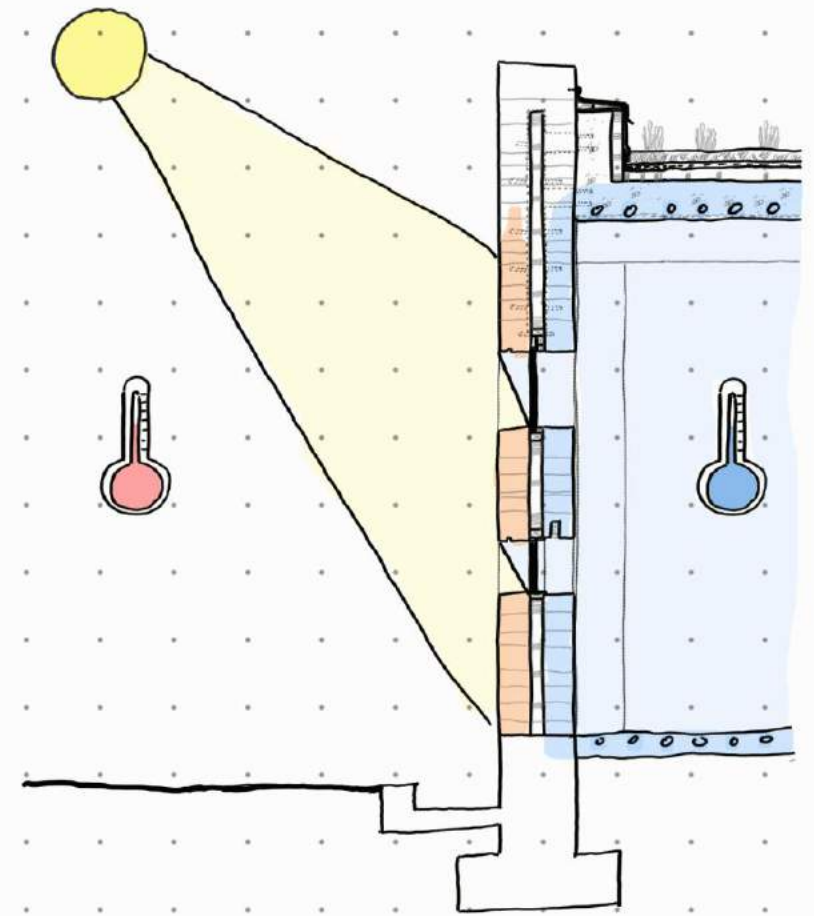
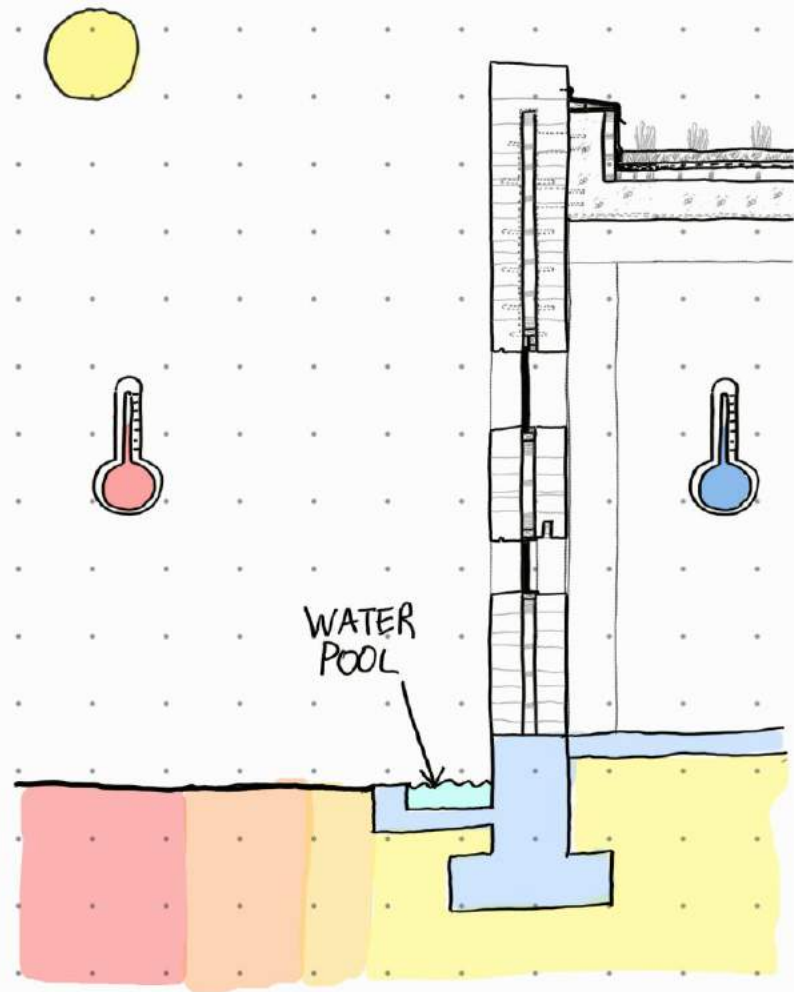

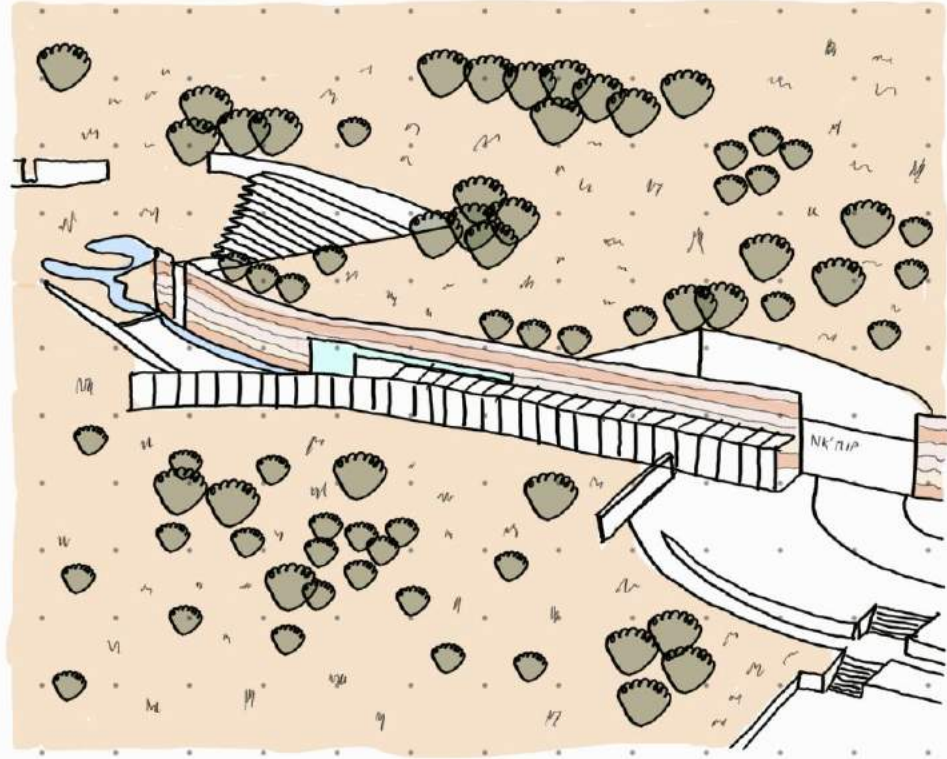

Osoyoos' desert centre 3D sketch

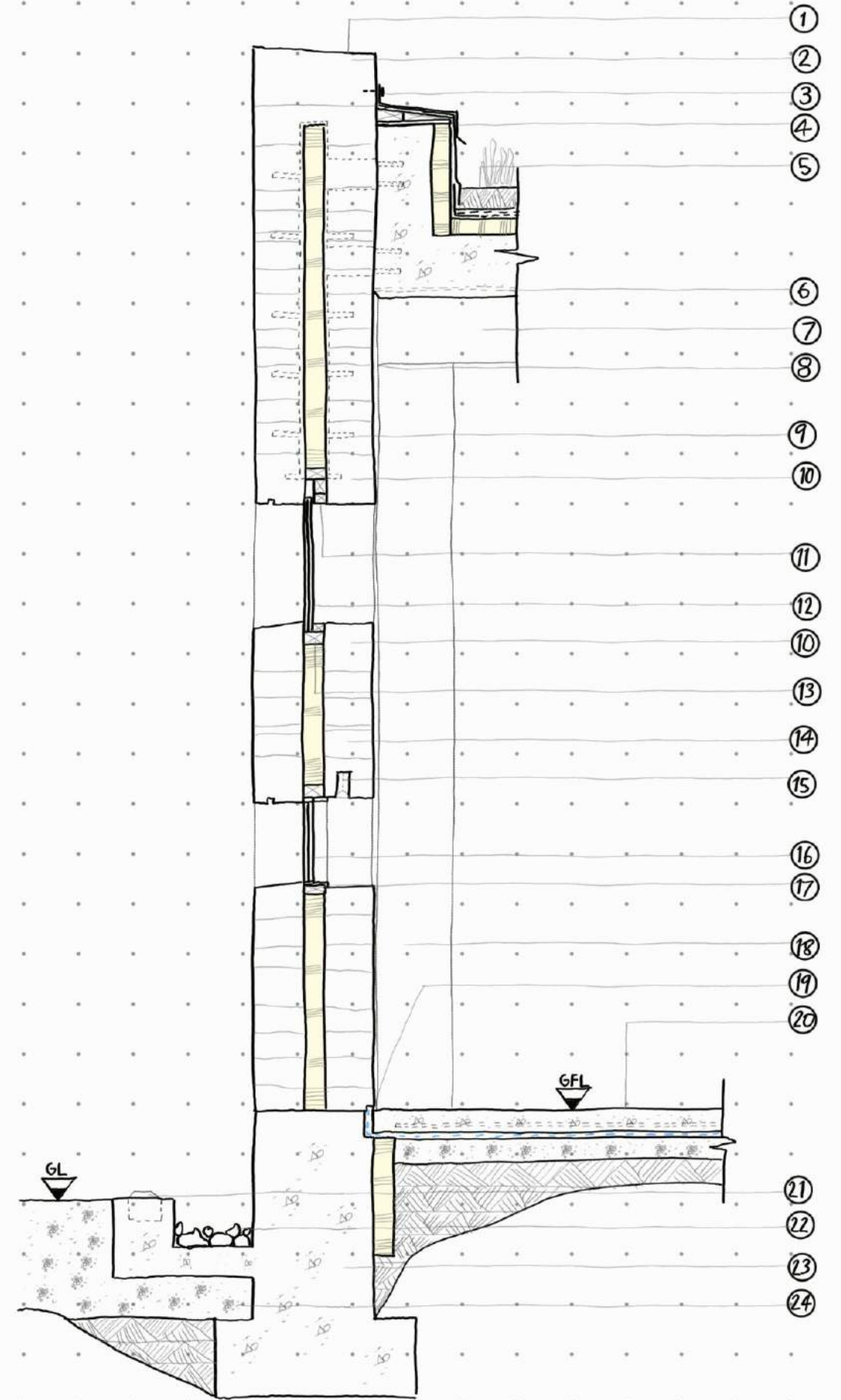

Osoyoos' desert centre 1:20 section

